

98770 CE Handbook

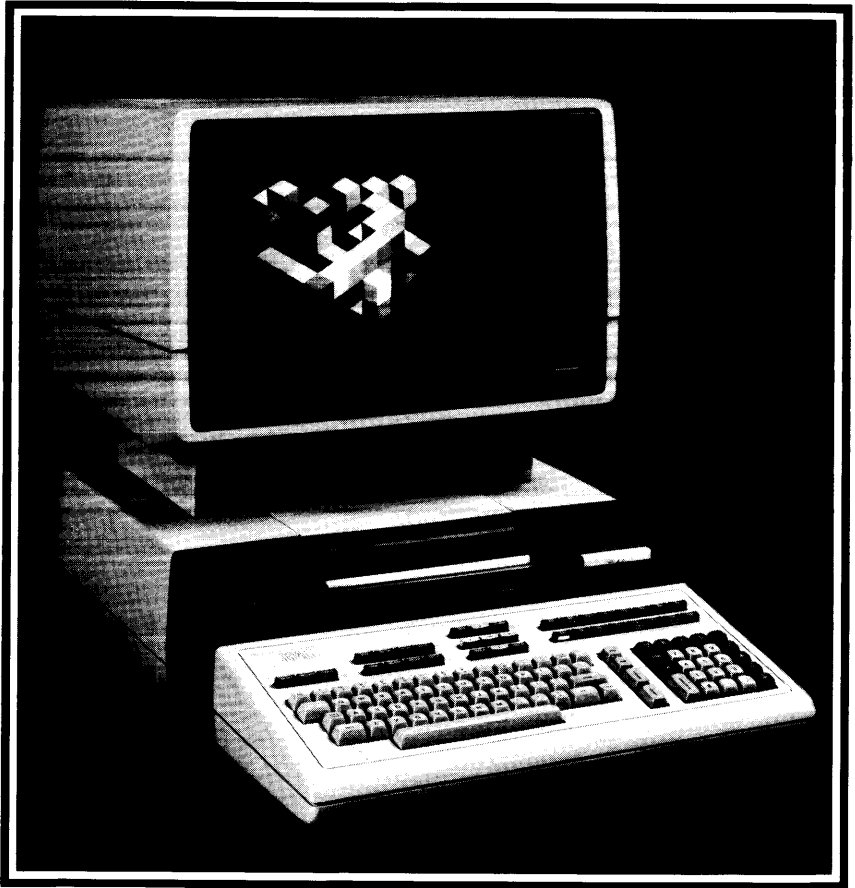

98770 CE Handbook

© Copyright 1982, 1983, Hewlett-Packard Company.

This document contains proprietary information which is protected by copyright. All rights are reserved. No part of this document may be photocopied, reproduced or translated to another language without the prior written consent of Hewlett-Packard Company. The information contained in this document is subject to change without notice.

Restricted Rights Legend

Use, duplication, or disclosure by the Government is subject to restrictions as set forth in paragraph (b)(3)(B) of the Rights in Technical Data and Software clause in DAR 7-104 9(a).

Hewlett-Packard Company
3404 East Harmony Road, Fort Collins, Colorado 80525

Chapter 1
98770 Product Information

Chapter 2
98770 Environmental Installation/PM

Chapter 3
98770 Configuration

Chapter 4
98770 Troubleshooting

Chapter 5
98770 Diagnostics

Chapter 6
98770 Adjustments

Chapter 7
98770 Peripherals

Chapter 8
98770 Replacement Parts

Chapter 9
98770 Diagrams

Chapter 10
98770 Reference

Chapter 11
98770 Service Notes

Printing History

New editions of this manual will incorporate all material updated since the previous edition. Update packages may be issued between editions and contain replacement and additional pages to be merged into the manual by the user. Each updated page will be indicated by a revision date at the bottom of the page. A vertical bar in the margin indicates the changes on each page. Note that pages which are rearranged due to changes on a previous page are not considered revised.

The manual printing date and part number indicate its current edition. The printing date changes when a new edition is printed. (Minor corrections and updates which are incorporated at reprint do not cause the date to change.) The manual part number changes when extensive technical changes are incorporated.

First Edition...October 1982

Second Edition...October 1983

Warranty Statement

Hewlett-Packard products are warranted against defects in materials and workmanship. For Hewlett-Packard Fort Collins Systems Division products sold in the U.S.A. and Canada, this warranty applies for ninety (90) days from the date of delivery.* Hewlett-Packard will, at its option, repair or replace equipment which proves to be defective during the warranty period. This warranty includes labor, parts, and surface travel costs, if any. Equipment returned to Hewlett-Packard for repair must be shipped freight prepaid. Repairs necessitated by misuse of the equipment, or by hardware, software, or interfacing not provided by Hewlett-Packard are not covered by this warranty.

HP warrants that its software and firmware designated by HP for use with a CPU will execute its programming instructions when properly installed on that CPU. HP does not warrant that the operation of the CPU, software, or firmware will be uninterrupted or error free.

HEWLETT-PACKARD MAKES NO WARRANTY OF ANY KIND WITH REGARD TO THIS MATERIAL, INCLUDING, BUT NOT LIMITED TO, THE IMPLIED WARRANTIES OF MERCHANTABILITY AND FITNESS FOR A PARTICULAR PURPOSE. Hewlett-Packard shall not be liable for errors contained herein or for incidental or consequential damages in connection with the furnishing, performance or use of this material.

* For other countries, contact your local Sales and Support Office to determine warranty terms.

Chapter 1

Product Information

98770A Specifications

Environmental Range

Operating Temperature:	+5°C to +40°C ambient
Storage Temperature:	-40°C to +65°C
Ambient Humidity:	<80%

Size/Weight

Height:	32 cm
Width:	46 cm
Depth:	45 cm
Net Weight:	29.45 kg (65 lbs.)

Power Requirements

AC Line Voltage:	110 volts ac (88 to 127 Vac) 220 volts ac (198 to 250 Vac)
Line Frequency:	48 to 66 Hz (inclusive)
Power Consumption	500 watts maximum (typical)

Display Features

Cathode Ray Tube:	14 inch diagonal, delta-gun, black matrix
Scan:	Non-interlaced raster scan
Refresh Rate:	60 Hz
Vertical Scan Rate:	60 Hz
Vertical Retrace Time:	1.03 milliseconds
Horizontal Scan Rate:	29.1 kHz
Horizontal Retrace Time:	10.2 microseconds
Dot Scan Rate:	29.7984 MHz

Alphanumeric Display

Alpha Raster Size	247 mm x 154 mm (720 dots x 455 dots) ¹
Screen Capacity:	2400 characters (30 lines of 80 characters) ²
Character Font:	7 dot x 9 dot in a 9 x 15 matrix
Character Size:	2.40 mm wide x 3.09 mm high (7 x 9 character)
Character Colors:	Black, white, red, green, blue, cyan, magenta, yellow
Standard Character Set:	128 ASCII characters
Additional Character Sets:	European, Katakana
Cursor:	White blinking underline
Highlighting:	Inverse video, blinking and underline

Graphics Display

Graphics Raster Size:	192 mm x 154 mm (560 dots x 455 dots)
Matrix Size:	560 dots x 455 dots (254,800 addressable points)
Bits Per Point	3 (one for each electron gun)
Graphics Colors:	Black, white, red, green, blue, cyan, magenta, yellow
Graphics Cursor:	Full-screen and small crosshair, blinking underline
Resolution:	Dots are spaced .343 mm center to center
Vector Drawing Speed:	Approximately 10,000 inches per second

Modifications for 9000 Series 500 Model 20

The 98770A display unit is used with the 9000 computers and must be modified by the addition of a printed circuit board. This board is installed inside its own housing that is attached to the underside of the display housing. This board forms the interface between the 98770A and the 9000 computer. The service information is contained in the Service Manual for the 9000 computers. (HP part number 09020-90038)

¹ The 98770A is capable of displaying a 247 mm x 154 mm raster (720 dots x 455 dots). This raster is displayed when using the A13 test switch, the self test fixture and the binary test cartridge. The 9845C does not use all of this area. During normal alpha operation, the alpha raster size is 247 mm x 144 mm (720 dots x 420 dots).

² The 9845C only uses 28 of the 30 lines.

Options and Configurations

The 98770A is available as either a part of the 9845C or as part of the 98771A Upgrade Kit.

Available accessories are:

98775A	Light Pen	(Also available as 9845C #775 or 98771A #775)
98776A	RGB Interface	(Also available as 9845C #776 or 98771A #776)
98777A	Camera Attachment	

Available character sets are:

9845C	ASCII/European	(Also 98771A standard)
9845C #840	Katakana	(Also 98771A #772)

Related Documentation

98770-90032	Service Manual
09845-92051	Color Graphics Programming Manual
09845-93005	Installation, Operating, and Test Manual
98770-90039	CE Handbook Section

Product Support Package

98770-66527	Test Fixture
98770-90031	Service Manual
09845-91031	Test Cartridge (TBIN)
09845-92041	System Exerciser Cartridge (B/C)
09845-93005	Installation, Operation and Test Manual

Safety

WARNING

LETHAL VOLTAGES ARE PRESENT INSIDE THE 98770A. REFER TO THE 98770A SERVICE MANUAL FOR GENERAL SAFETY GUIDELINES.

Chapter 2

Environmental/Installation/ Preventive Maintenance

Installation

The display assembly fits into place over the mainframe support legs. Early units did not have locking hardware on the feet; current units do. If the hardware is there, lock it.

CAUTION

THE 98770A RELIES ON THE MAINFRAME TOP COVER FOR WEIGHT SUPPORT. THE MAINFRAME TOP COVER MUST BE INSTALLED BEFORE INSTALLING THE 98770A.

WARNING

THE 98770A IS HEAVY (29.45 KILOGRAMS OR 65 POUNDS). TO AVOID INJURY, ENLIST THE AID OF A SECOND PERSON WHEN LIFTING THE 98770A. IF HELP IS NOT AVAILABLE, LIFT FROM REAR OF THE UNIT.

Initial Turn-On

CAUTION

THE 98770A HAS NO POWER SWITCH. IT IS SWITCHED ON VIA A RELAY WHICH IS ACTIVATED WHEN THE 9845C MAINFRAME IS SWITCHED ON. ALWAYS SWITCH THE 9845C POWER SWITCH TO THE OFF POSITION BEFORE CONNECTING THE 98770A POWER CORD.

Before applying power to the computer, check the following items:

- 98770A is properly installed.
- Voltage selector switches set properly on both display and mainframe.
- Proper fuse installed in both display and mainframe.
- Power switch set to off.
- Power cords connected to both display and mainframe.

Switch the power switch on. After a 20-second (approximate) warmup time, the message "9845 READY FOR USE" will appear on the CRT display, followed by the blinking cursor. Adjust the intensity control located beneath the lower left corner of the CRT bezel for the desired display intensity. If the turn-on memory test fails, "PART OF MEMORY FAILED SELF-TEST" is displayed.

Preventive Maintenance

Clean the case parts and tube face occasionally with mild soap and water or alcohol. Do not use harsh, abrasive, or other general purpose cleaners. Use care to assure that no liquid gets inside of case.

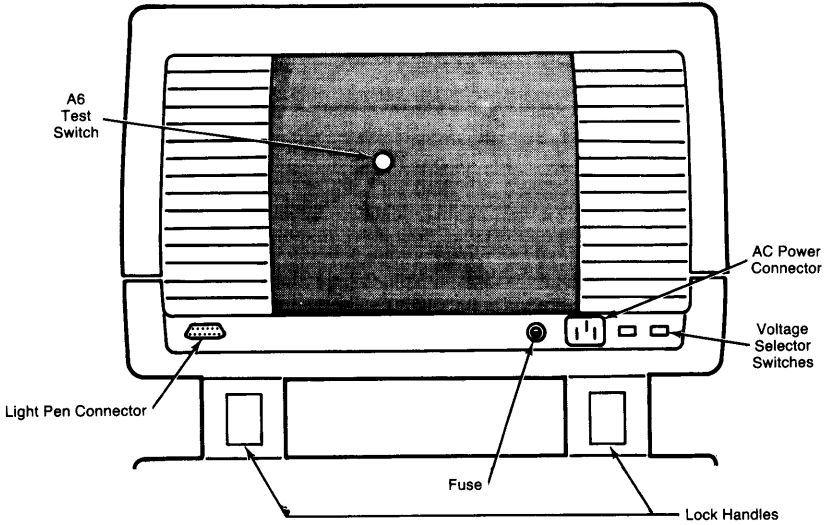

Figure 2-1. 98770A Back Panel

Chapter 3

Configuration

Base Configuration

The following assemblies must be installed in the 9845C base to support the 98770A. (These parts are included in the 98771A Upgrade Kit.)

98770-65501 Color graphics ROM	98780-65501 Enhanced graphics ROM
1818-1208 Mainframe ROM	1818-1591 Mainframe ROM
1818-1209 Mainframe ROM	1818-1592 Mainframe ROM
or for either	
98770-66534 Alpha control assembly	
(replaces 09845-66503 in Mainframe)	

See the 9845B CE Handbook Chapter for locations of these parts.

Interfacing

The 98770A interfaces to the 9845C base via the Alpha Control Assembly (98770-66534) and the Graphics Interface Assembly (09845-66504). Alpha information is stored in block 0 read-write memory, and is refreshed to the display via the IDA bus. Graphics information is transferred via the I/O bus to the display, where it is interpreted and entered into the display memory.

Status Word

The Status Word may be obtained by executing the following instructions:
(requires I/O ROM installed in mainframe)

```
STATUS 13;A
DISP A
```

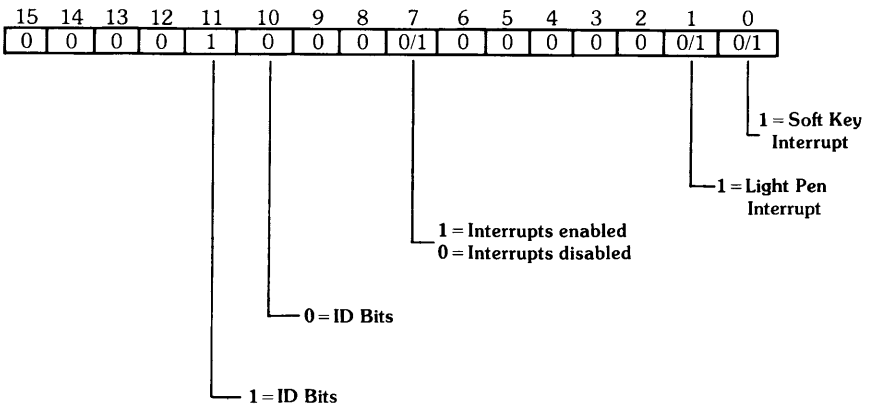

3-2 98770 Configuration

Chapter 4

Troubleshooting

Initial Checks

Check	Action
Is the base operating? (Try PRINTER IS 0 PRINT "HELLO")	Yes - Proceed with Initial Checks. No - Fix base.
Is there any display?	Yes - Proceed to Raster Checks No - Proceed with Initial Checks.
Adjust intensity control. Press control-stop Is there a cursor?	Yes - Proceed to Raster Checks. No - Proceed with Initial Checks.
Check voltage select switches, fuse, and line power.	Correct any fault.
Still no display?	Proceed to Inoperative Unit Checks.

Inoperative Unit Problem Chart

(Remove top cover.)

Symptom	Probable Cause
Fuse keeps blowing.	Fault in: Power Supply Rear Panel Assembly Transformer Spark Gap
Neither back panel fan runs.	Fault in: Rear Panel Assy Turn-On Relay Transformer Fuse located below power supply (early units only).
Fan above voltage selector switches doesn't run.	Fault in: Power Supply or other area of unit. (See Power Supply Indicators). Fan
	Proceed to Inoperative Unit Problem Chart - Power Supply Indicators.

Inoperative Unit Problem Chart Power Supply Indicators

Located on top left side of 98770 as you face front of display. See Page 9-8 this handbook.

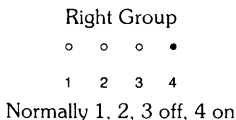
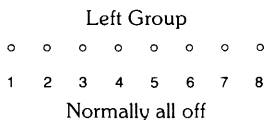

Indication	Cause
Left	
1	- 80V overcurrent. High Voltage, A44, A5, A6
2	- 80V overvoltage. A44, A5, A6, High Voltage
3	+/- 15V or +/- 25V overvoltage. A5, A44, A3, A2, A6
4	+ 12V overvoltage. A44, A5
5	A5 Heat Sink over-temperature. A5, defective fan, blocked air inlet.
6	Switching transformer primary overcurrent.
7	- 5.2V overvoltage. A5, A6, A32, A13 (A33, A53, A54), Light Pen A2
8	+ 5V overvoltage. A32, A11, A13 (A33, A53, A54), A6, A2
RIGHT	
1	Linear 2 Switching Regulator inhibited. A5, Power Supply
2	Linear 1 Switching Regulator inhibited. Power Supply
3	Logic Switching Regulator inhibited.
4	Normally on to indicate +/- 15V INT is present. If off, power supply is inhibited.

Inoperative Unit (Remove top cover)

CAUTION

BEFORE REMOVING OR INSTALLING ANY ASSEMBLY DISCONNECT UNIT FROM POWER SOURCE BY REMOVING POWER CORD FROM BACK OF UNIT.

Note

As viewed from rear of unit the left-hand fan is ac powered, the right-hand fan is dc powered.

Turn Unit ON

If no display, then observe Power Supply Indicators. See page 4-2.

Observe the fans. If the ac fan (left-hand) is not turning, check:

- a. Fuse
- b. Power source (wall connector, power cord, etc.)
- c. Computer (use the turn-on fixture)
- d. Primary wiring

Note

If the ac fan starts turning as soon as the power cord is connected, the power-on relay controlling it may be stuck closed.

If the ac fan is turning but the dc fan (right-hand) is not, check:

1. Number 4 LED in the right indicator group. If lit (brite), power supply is functional. Skip to Step 2.
2. If off (dark), Power supply is not powered or inoperative. Replace power supply and A5 assembly and do this section again. (see A5 and power supply procedure See Page 4-8.)

Check Which LED's Are Lit

The following list is for **Left** indicator group of LED's unless otherwise stated.

LED #1 Lit

– 80 Volt supply overcurrent.

1. Unplug power cord .
2. Disconnect high voltage assembly.
3. Plug in and turn on (no display will be visible).
 - a. All LED's dark, unplug power cord and replace H.V. assembly.
 - b. LED #1 still ON, unplug and remove A6 board.
4. Plug in and turn on.
 - a. All LED's dark, unplug power cord and replace A6 board.
 - b. If LED #1 still lit, go to minimum configuration tests See Page 4-5.

LED #2 Lit

– 80 Volt supply overvoltage.

1. Unplug power cord .
2. Replace A5 and Power supply.
(See A5 and Power Supply procedure See Page 4-8.)
3. Plug in and turn ON. (no display will be visible). If LED #2 still lit, go to minimum configuration tests See Page 4-5.

4-4 98770 Troubleshooting

LED #3 Lit

± 15 or ± 25 Volt Supply overvoltage.

1. Unplug power cord.
2. Do A5 and Power Supply procedure See Page 4-8.
3. Plug in and turn ON. If LED #3 still lit, go to minimum configuration tests.

LED #4 Lit

+ 12 Volt Supply overvoltage.

1. Unplug power cord.
2. Do A5 and power supply procedure See Page 4-8.
3. Plug in and turn ON. If LED #4 still lit, go to minimum configuration tests.

LED #5 Lit

A5 heatsink temperature higher than 100° C.

1. Check air flow of internal fan (near bottom of heatsink) by holding hand above A5 heat sink.
2. No air flow. Unplug power cord.
3. Remove A5 and try to rotate fan by hand.
 - a. If frozen (will not rotate), replace fan.
 - b. If it spins, disconnect the fan and check the voltage at the connector (25 Vdc). Check the wiring to fan. See Page 9-3, 9-4, 9-5.
4. Do A5 and power supply procedure See Page 4-8.
5. Plug in and turn ON. If LED #5 still lit, go to minimum configuration tests.

LED #6 Lit

Switching transformer primary overcurrent.

1. Unplug power cord.
2. Replace power supply.

LED #7 Lit

- 5.2 supply overvoltage.

1. Do A5 and power supply procedure. See Page 4-8.
2. Go to minimum configuration tests, Page 4-5.

LED #8 Lit

+ 5 Volt supply overvoltage.

1. Replace A5 board. See Page 4-8.
2. Go to minimum configuration tests. See Page 4-5.

Right Indicator Group

LED #1 or #2 or #3 lit.

1. Replace Power Supply.
 - a. Do A5 and Power Supply procedure See Page 4-8.

Minimum Configuration Tests

Use this procedure when the unit has an inoperative power supply or will not indicate the presence of ± 15 Volts dc. or when primary wiring defects are suspected.

Minimum Configuration

Minimum configuration consists of:

1. Base assembly and mother board.
2. Power supply and primary wiring.
3. A5 board (98770-66505).
4. A44 board (98770-66544).
5. Turn on fixture or installed on Computer.

CAUTION

DO NOT RUN UNIT IN MINIMUM CONFIGURATION FOR MORE THAN 30 SECONDS AT A TIME. (MINIMUM PLUS A33 BOARD CAN BE RUN INDEFINITELY.)

To achieve minimum configuration, remove:

1. The A6 board (98770-66506).
2. The A11 board (98770-66511).
3. The A32 board (98770-66532).
4. The A33 board (98770-66533/13/53/54).
5. The 98775-66501/66504 board if present.
6. Three 503 boards (98770-66503). Note the order of removal to avoid reconvergence.
7. The 502 board (98770-66502).
8. Remove the CRT assembly (be careful to disconnect YOKE wiring under the CRT).

Preliminary Procedure

Plug unit into power source and listen to "wake-up" sounds as you turn unit on (ignore LEDES when base is turned OFF):

- a. Relay closure click in top.
- b. All fans turning.
- c. Steady beep from base is normal. There is no handshake.
- d. Watch LED's. If any LED lit, do A5 and Power Supply Procedure. #4 LED in right indicator group normally lit (brite).
- e. Retest. If LED still lit, replace A44 or Mother board (Rare).
- f. Unplug unit.

Unit must pass the minimum configuration tests before proceeding to next page.

Unit Rebuild

Do minimum configuration tests before proceeding with unit rebuild.

CAUTION

BEFORE REMOVING OR INSTALLING ANY ASSEMBLY DISCONNECT UNIT FROM POWER SOURCE BY REMOVING POWER CORD FROM BACK OF UNIT.

1. Install the A33 Board and test run.
 - a. Pass - Power supply comes up, #4 LED lit, all other LED's dark, no beep from mainframe.
 - b. Fail - If any LED lit, except #4, replace A33 board.
 - c. Test run (repeat Step 1).
2. Install the CRT and Yoke assembly. Make all connections to Yoke, but do not connect high voltage.
 - a. Pass - Power supply comes up, #4 LED lit, all other LED's dark.
 - b. Fail - If any LED lit, except #4, replace CRT and Yoke assembly.
 - c. Test run (repeat Step 2).
3. Connect high voltage.
 - a. Pass - Power supply comes up, #4 LED lit, other LED's dark, listen for HV crackle.
 - b. Fail - If any LED lit, except #4, replace high voltage assembly.
 - c. Test run (repeat Step 3).
4. Install the A6 assembly. Install all mounting screws.
 - a. Pass - Power supply up, display visible but no horizontal sync. (Retrace lines visible, convergence close but colors separated, no alpha, no graphics). #4 LED lit, other LED's dark.
 - b. Fail - Replace A6 assembly
 - c. Test run (repeat Step 4).
5. Connect Video cable from A33 to A6. Assure that the cable keys mate correctly.
 - a. Pass - Power supply up, Alpha display, convergence close but colors separated, no retrace lines. (If retrace visible, recheck cable for proper key.)
 - b. Fail - Double check cable key. Replace A33 board.
 - c. Test run (repeat Step 5).
6. Install the three 503 boards, one at a time (remember the order they were removed in)
 - a. Pass - Turn on after installing each board. Power supply up, Alpha, convergence close but colors separated, no retrace.
 - b. Fail - Replace the 503 board just installed.
 - c. Test run after each 503 is installed (repeat Step 6).

7. Install the 502 board. Do not connect the cable.
 - a. Pass - Power supply up. Alpha present, convergence close but colors separated, no retrace.
 - b. Fail - Replace the 502 board.
 - c. Test run (repeat Step 7).
8. Connect the cable on the 502 board.
 - a. Pass - Power supply up. Normal display, convergence close to normal.
 - b. Fail - Double check the cable. Replace the 502 board.
 - c. Test run (repeat Step 8).
9. Install the 511 board.
 - a. Pass - Power supply up. No change in display.
 - b. Fail - Replace the 511 board.
 - c. Test run (repeat Step 9).
10. Install the A32 board.
 - a. Pass - Power supply up. No change in display.
 - b. Fail - Replace the A32 board.
 - c. Test run (repeat Step 10).
11. Install the 98775-66501 board (if present).
 - a. Pass - Power supply up. No change in display.
 - b. Fail - Replace the 98775-66501 board.
 - c. Test run (repeat Step 11).
12. Connect the video cable. Assure that the cable keys mate (if 98775-66501 present).
 - a. Pass - Power supply up. No change in display.
 - b. Fail - Replace the cable or the 98775-66501 board.
 - c. Test run (repeat Step 12).
13. Do complete diagnostics and alignment.
Return to preliminary checks.

A5 and Power Supply Replacement Procedure

CAUTION

BEFORE REMOVING OR INSTALLING ANY ASSEMBLY DISCONNECT UNIT FROM POWER SOURCE BY REMOVING POWER CORD FROM BACK OF UNIT.

Turn OFF and unplug unit.

Replace both A5 and power supply with known good, new assemblies. If unit does not function properly, A5 or power supply is not the problem. Turn OFF, unplug and reinstall original A5 and power supply. Check out the primary wiring and the mother board assembly. Return to Inoperative Unit procedure or Minimum Configuration procedure.

If unit does function, do the following steps:

1. Remove new supply and reinstall original supply leaving new A5 installed. Plug in and turn ON.
 - a. If unit operates, A5 is the problem. Leave new A5 in unit.
 - b. If unit still does not operate, supply is the problem. Reinstall the new supply. Leave new A5 in unit.
2. Return to Minimum Configuration Procedure.

Raster Problem Chart

Symptom	Cause
No display	Check Power Supply Indicators
Improper focus control.	High voltage, A44, CRT
No high voltage.	High Voltage, A44, A5, Power Supply
No raster deflection.	Yoke Assembly A44, A5.
Odd raster shapes.	A44, A5
Other raster-related problems.	A44, A5
Improper intensity settings.	
Color always on or off.	Cable not connected, A6, A13 (A33, A53, A54), 98775-66501/66504.
Loss of one color.	A6, A13 (A33, A53, A54), CRT
Improper purity.	A2
Improper blue lateral.	A2, A5
Improper convergence.	A3, A2, A5
Cannot converge one color.	A3, A5
Retrace lines on before desired intensity reached.	A6
Retrace lines "On" at power-up.	Cable to A6 disconnected. A6, A13 (A33, A53, A54), 98775-66501/66504.

Graphics Problem Chart

Symptom	Cause
Incorrect lines being drawn.	A11
Extra or missing lines.	A11
Improper or no area fill.	A11
Improper line type or no line type control.	A11
Random or repetitive dots missing or always on display.	A32
Intermittent display dots.	A32
Groups of dots missing or always displayed.	A32
Cannot read or write into graphics memory.	A32
Softkey problem (no decoding)	A11, cable, softkey switches.

Alpha Problem Chart

Symptom	Cause
No alpha display.	A13, (A33, A53, A54), A34
No graphics display.	A13, (A33, A53, A54), A11, A32, 98775-66501/66504
Improper or incorrect characters.	A13, (A33, A53, A54), A34
Characters missing (character in lines) or incorrect.	A13, (A33, A53, A54), A34
Incorrect colors or highlighting.	A13, (A33, A53, A54), A34
One or more cursors missing or incorrect.	A13, (A33, A53, A54)
No alpha blanking.	A13, (A33, A53, A54)
No graphics blanking	A13, (A33, A53, A54)

Chapter 5

Diagnostics

Test Binary Diagnostics

1. Use the 9845B/C Test Binary Cartridge 09845-91031 (Rev. C or newer.)
2. Install the cartridge in T15.
3. Key in: LOAD BIN "TBIN" **EXECUTE**.
4. Menu displayed.
5. Press **k0** or **k5**.
6. Table 5-1 is a listing of the tests contained on the disc. The procedures for individual tests start on the next page. (page 5-3).

Table 5.1 Test Binary Display Tests

Alpha Tests Key	Test
B	Alpha display buffer test
F	Focus adjustment pattern
+	Convergence alignment pattern
C	Character set with highlighting features and color
O	Optional character set with highlighting and color
S	Color and highlighting in various combinations
A	Alpha on and off test

Graphics Tests Key	Test
k8 - k15	Full graphics raster in different colors (one color per key)
M	Graphics memory test
K	Displays the three graphics cursors
k0 - k7	Changes the graphics cursor color (one color per key)
X	Grid based on present graphics cursor position
V	Vectors and linearity
G	Graphics on and off test
→	Moves graphics cursor in direction of arrow

Other Tests Key	Test
Soft Keys	Soft key test
P	Light pen test

Alpha Tests

Alpha Display Buffer Test

Press ; the CRT displays:

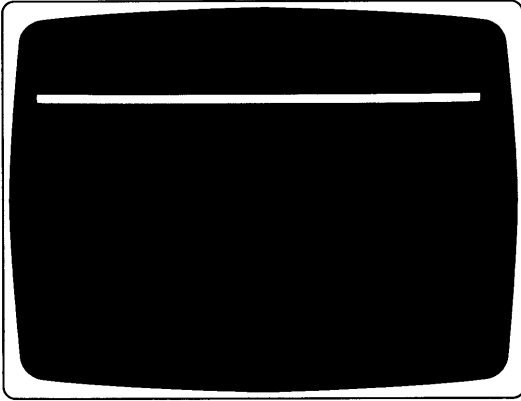

This test checks the 80-character line buffers on the A34 assembly, plus the ability to display information.

Focus Alignment Pattern

Press ; two columns of the word "FOCUS" appear. Check the characters to ensure they are clear and readable. If necessary, remove the display's top cover and adjust the focus control to achieve the best overall character focus (refer to Chapter 6 for adjustment procedures). It may not be possible to achieve perfect focus in all areas of the display.

Convergence Alignment Pattern

Press ; all thirteen '+'s and the corresponding step number are displayed. Use this display for a quick convergence check and for any touch-ups.

C **Character Set With Highlighting Features and Color**
 Press **C**; the CRT displays:



Note

To see black, press one of the graphics color keys, **k8** through **k15**.

This test checks the character ROM and the highlight and color latch on the A13, A33, A53, or A54 assembly.

0 **Optional Character Sets**

Press **0**; if an optional character ROM is installed (Option 771 or 772), the optional characters are displayed.

If test fails replace the A13 (A33, A53, A54) assembly

Note

If the optional character ROM is not installed, inverse video characters will be displayed.

S **Color and Highlighting in Various Combinations**
Press **S**; the CRT displays:

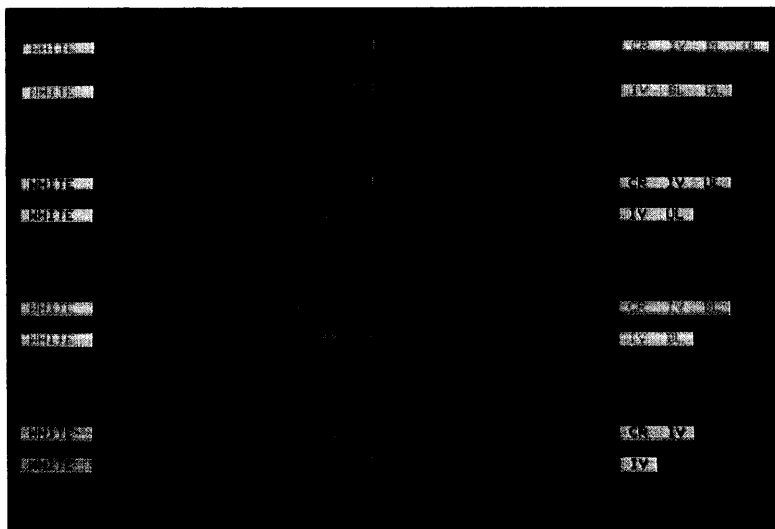

Note

To see black, press one of the graphics color keys, **ks** through **kts**.

If test fails replace the A13 (A33, A53, A54) assembly

A **Alpha On and Off Test**

Press **A**; the alpha display should disappear. Press **A** again, the alpha display should appear again. Press **A** again to enable next test.

This test checks the alpha blanking circuit on the A13 (A33, A53, A54) assembly.

Graphics Tests

k8 - **k15** Full Graphics Raster in Different Colors

Press any key from **k8** through **k15** : a colored graphics raster will appear. Refer to Chapter 6, page 6-5, for color intensity adjustments.

Here is a summary of the keys and the color each key produces.

Key	Color
k8	White
k9	Red
k10	Yellow
k11	Green
k12	Cyan
k13	Blue
k14	Magenta
k15	Black

The test checks the graphics memory and color assignment logic on the A32 assembly.

M Graphics Memory Test

Press **M** ; the three graphics memories on the A32 assembly are tested.

Memory errors are displayed on the following format:

Example	X Dot Location	Y Dot Location	Memory Number	Actual Data	Expected Data
GRAPHICS	X:00000	Y:00000	MEM#:00000	HAS 000000	NOT 000000

The 98770A Service Manual shows how to isolate this error message to a single memory chip.

K Graphics Cursors

Press **K** ; initially the small horizontal line cursor (—) appears. Press **K** again and the full screen cross-hair cursor appears. Press **K** once more to view the small cross-hair cursor.

This test checks the graphics cursor logic on the A13, A33, A53, or A54 assembly.

k0 - **k7** Graphics Cursor Color

Press any key from **k0** through **k7** to change the color of the graphics cursor. Here is a summary of the keys and the color cursor each key produces:

Key	Color
k0	White
k1	Red
k2	Yellow
k3	Green
k4	Cyan
k5	Blue
k6	Magenta
k7	Black

X Grid

Press **X** ; a grid is produced, based on the present position of the graphics cursor.

Vectors and Linearity

There are several sections to this test. Press anytime to return to main Menu.

Press ; the first display is five horizontal lines to be used for vertical linearity.

Using the alignment mask, ensure that the center line is aligned to the center line of the alignment mask. Then align the bottom and top lines with those on the mask. Refer to Chapter 6 for vertical linearity adjustment procedures.

Press ; the next pattern is vertical lines for horizontal linearity.

Press ; the following display appears:

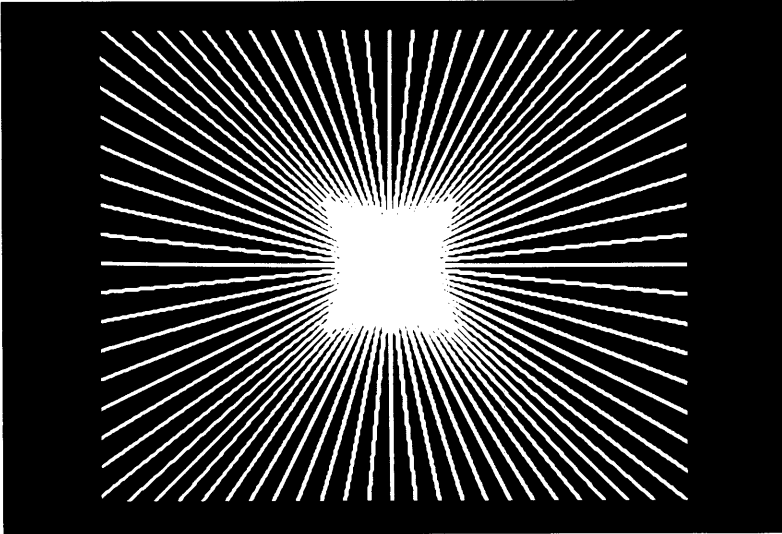

This display tests the ability of the vector generator to compute and draw vectors. The vector generator is on the A11 assembly.

Press **V** ; the display shows the 16 area fill patterns and the 8 line types.

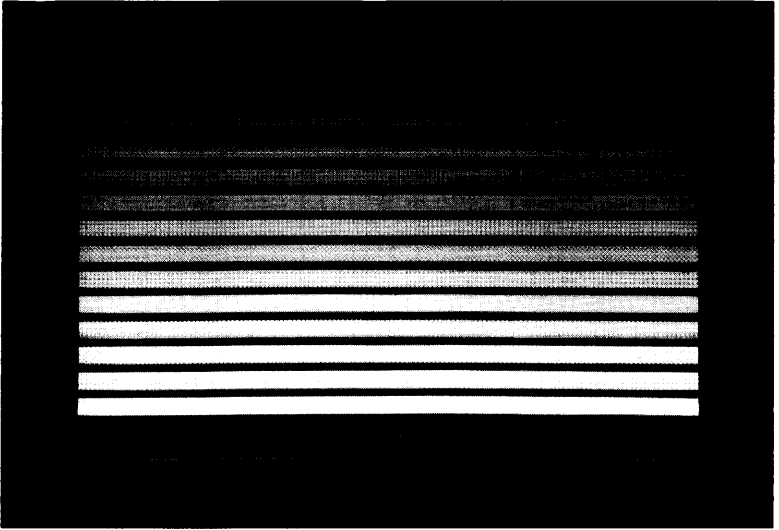

Press **V** ; the display shows three overlapping blocks. The three memories are assigned different colors for this section and the next two sections. The colors are rotated in the three memories.

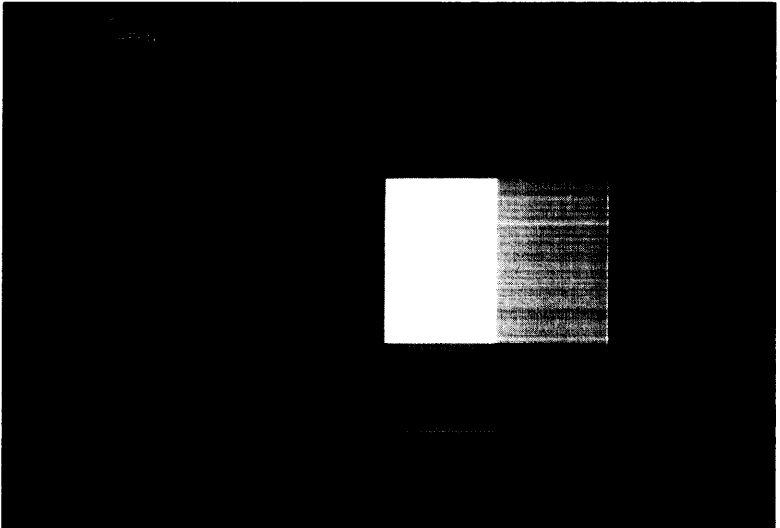

5-8 98770 Diagnostics

Press

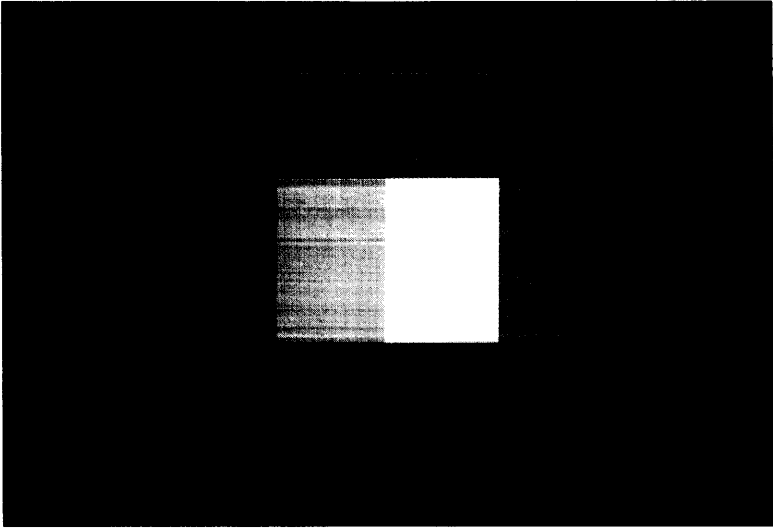

Press

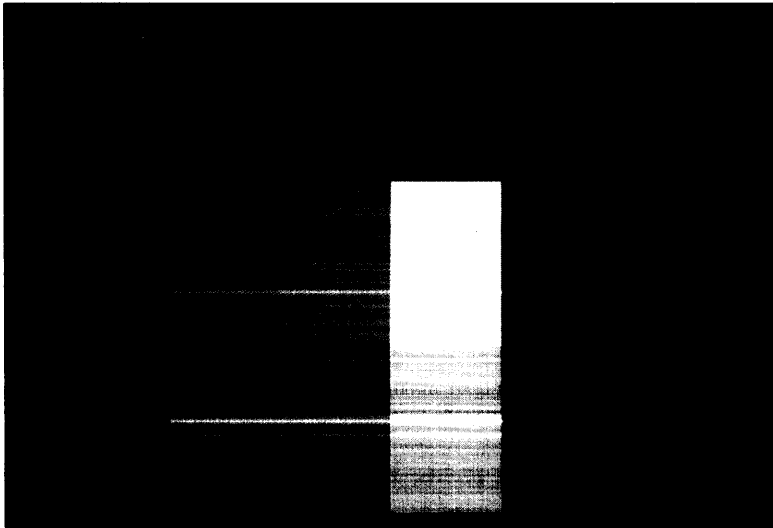

Press to return to the main program.

G Graphics On and Off Test

Press **G**; the graphics display should disappear. Press **G** again, the graphics display should appear again. This test checks the graphics blinking circuit on the A13 (A33, A53, A54) assembly.

Ensure that graphics is on and press the arrow keys to move the graphics cursor.

Move Graphics Cursor

The arrow keys allow graphics cursor movement within the graphics raster.

Other Tests**Soft Key Test**

Press each of the keys on the lower front bezel of the display. An X appears above the key that was pressed. Must be in Main Menu; not Graphics.

P Light Pen Test

Press **P**; a self test is performed on the light pen's position circuits.

Press **CONTINUE**; position the pen over the cursor and press the "pick" button. "ok" should appear on the display. This tests the ability of the light pen to pick a point.

Press **CONTINUE**; point the light pen at the cursor. Check the offset and field values.

The offset value should be 8 ± 3 .

The field value should be greater than 18.

Press **CONTINUE**; point the light pen at the cursor. A threshold shift test is performed. OK appears when the test passes.

9845B Test Tape Diagnostics

Refer to "Installation, Operation, and Test for the HP 9845" (09845-93005) shipped with each unit or to the 98780A CE Handbook chapter.

Chapter 6

Adjustments

Tools Required

#2 Pozidriv Screwdriver
 Alignment Tools (non-metallic)
 (Recommend HP part no. 8710-0033 and 8710-0933)

Adjustment Summary

Complete alignment of the 98770A is accomplished in the following order:

Adjustment	Page
Preliminary	6-3
High Voltage	6-3
Focus	6-4
Purity	6-4
Color Intensity	6-5
Convergence (Prelim)	6-6
Raster Position	6-7
Raster Size	6-7
Raster Shape	6-8
Vertical Linearity	6-10
Convergence (Final)	6-6

Where to Start Adjusting

Assembly Replaced	Start at (and do all subsequent)
CRT/Yoke	Preliminary Adjustments
High Voltage Unit	High Voltage
98770-66502	Purity
98770-66503	Convergence (Final)
98770-66506	Color Intensity
98770-66544	High Voltage

6-2 98770 Adjustments

A6 Adjustments

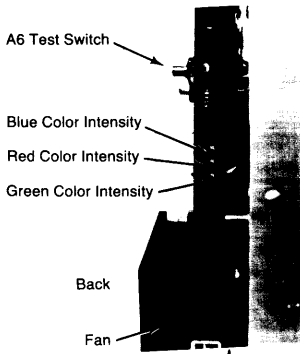

A44 Adjustments

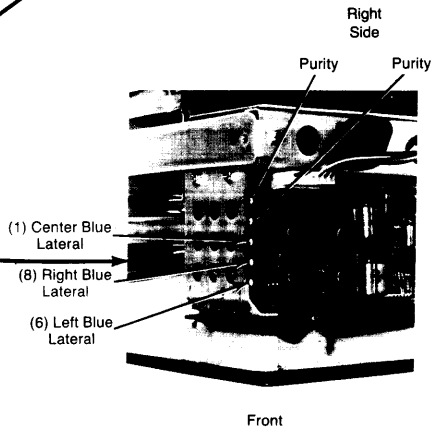
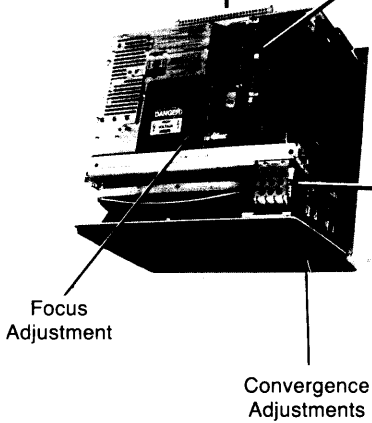
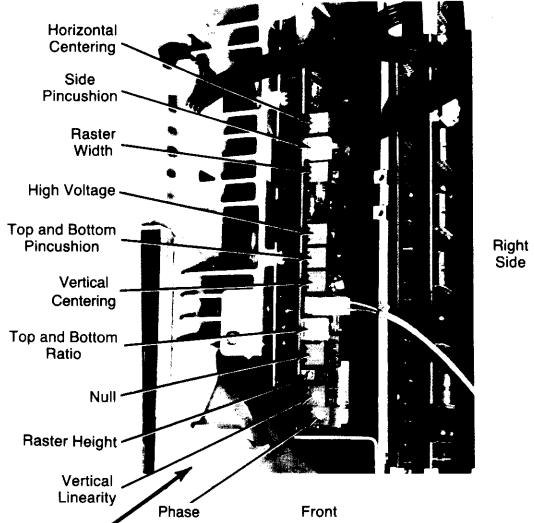

A2 Adjustments

Preliminary Adjustment

Use this adjustment procedure when adjusting a badly misaligned unit, or one in which the CRT/Yoke assembly has been replaced.

Procedure

1. Set the switch on the A13 (A33, A53, A54) assembly to its forward (red raster) position.
2. Turn the high voltage control (A44) fully CCW for the maximum high voltage.
3. Adjust the brightness control (under lower left edge of display unit) clockwise for a visible raster. If none appears, adjust the RED color intensity control (A6) until a raster appears.
4. Depress the A6 test switch and adjust the focus control for the sharpest retrace lines.
5. Adjust the two A2 purity controls for an even red color throughout the raster.
6. Adjust the A44 height, width, vertical, and horizontal centering so all raster edges are at least 1 cm inside the screen edges. Touch-up the A2 purity controls if necessary for optimum red purity.
7. Perform a preliminary color intensity adjustment per the procedure on page 6-5.

High Voltage

WARNING

DO NOT ATTEMPT TO MEASURE THE CRT ANODE VOLTAGE.

This adjustment sets the high voltage level for the CRT anode.

Note

If the A6 video drive assembly has been changed, perform a preliminary color intensity adjustment before proceeding.

Procedure

1. Set the switch on the A13 (A33, A53, or A54) assembly to its rear (white raster) position.
2. Set the brightness control to maximum.
3. Turn the High Voltage adjustment (A44) fully CCW for maximum high voltage.
4. Turn the High Voltage adjustment until the raster increases in width by approximately 0.5 cm on each side.

Focus

Use this adjustment (High Voltage Unit) to set the CRT focus grid voltage to a value which gives the best overall character focus.

WARNING

USE A NON-CONDUCTIVE ALIGNMENT TOOL WHEN ADJUSTING THE FOCUS CONTROL.

Procedure

1. Set the A13 (A33, A53, A54) assembly to its center position.
2. Use the 9845B/C binary test cartridge (Rev. C or newer) to display the focus pattern. (Refer to Chapter 5.)
3. Turn the focus control to achieve the best overall display focus of the displayed characters.

Purity

This adjustment varies the current in the purity coils so that the beam from the red electron gun strikes only the red phosphor.

This adjustment is interactive with the Raster Position adjustment, and affects Convergence.

Procedure

1. Execute "DEGAUSS" from the keyboard. (Exit Test Binary first by pressing **K15**).
2. Set the A13, A33, A53 or A54 switch forward for a red raster.
3. Adjust the brightness control and the color intensity control (A6) as necessary to produce a medium-bright red intensity level.
4. Adjust the A44 width, height, and centering controls until all raster edges are visible.
5. Turn the vertical and horizontal purity controls (A2) to obtain a pure red raster.
6. Readjust the raster position.

Note

If good purity cannot be achieved, decrease the brightness, wait a few minutes, and repeat the purity adjustment procedure. High intensities can overheat and warp the CRT shadow mask which will affect purity. This warpage is not permanent and will disappear when the intensity is reduced to a normal level.

Color Intensity

This adjustment sets the screen grid bias for the red, blue, and green electron guns to proper levels.

In a complete alignment, this adjustment must be done twice because it both affects and is effected by other adjustments. A rough color intensity adjustment should be done prior to high voltage adjustment, and a fine adjustment should be done prior to convergence.

Set the switch on the A13 (A33, A53, A54) assembly to the rear position to display a white raster. Turn the brightness control to the minimum brightness position (full CCW).

Procedure

Perform this procedure in normal room lighting.

WARNING

BEWARE OF THE FANS WHEN MAKING ADJUSTMENTS WITH THE REAR PLASTIC COVER REMOVED.

1. Adjust the 3 color intensity controls (CCW) (A6) until none of the three rasters are visible. (Use an insulated tool only.) If necessary, remove the metal shield.

WARNING

REMOVING THE METAL SHIELD EXPOSES LETHAL VOLTAGES PRESENT ON THE A6 ASSEMBLY.

2. Adjust the green color intensity control clockwise to produce a dim but entirely visible green raster. Turn this control 1/3 turn more CW from this setting.
3. Adjust the red and blue color intensity controls to cause the raster to appear gray and very slightly increased in brightness from step #2.
4. Turn the brightness control slowly toward maximum brightness, looking for any dominant color or tint appearing as the raster changes from gray to white.
5. Adjust the appropriate color intensity control to minimize any objectional color tinting over the brightness range from gray to white. Disregard tinting in small areas which may be related to misconvergence or less-than-perfect purity.

Convergence

This adjustment converges the red, green and blue electron beams so that as the beams scan across the display area, all beams scan in unison as one dot.

Set the switch on the A13 (A33, A53, or A54) assembly to its center position (Normal position).

Adjust brightness full CW (maximum brightness).

Procedure

1. From the keyboard, type in CONVERGE and press execute.
2. A "+" character will appear on the screen along with a number on the right-hand side.
 - The "+" character is used to converge the three beams in the area that the "+" appears.
 - The number on the right-hand side indicates the step number (13 total) and it appears directly opposite the convergence controls used for that step.
3. On all 13 convergence steps,
 - a. converge the red and green "+" to make yellow.
 - b. converge the blue "+" to make white.
 - c. If on Convergence steps 1, 6, or 8, refer to procedural step 4 below.
 - d. press **CONTINUE**
4. On steps 1, 6, and 8, you may have to adjust the blue lateral adjustments. (A2)

If the blue is to either side of the converged +, use the appropriate blue lateral adjustment to center the blue + horizontally on the converged red and green +.

On step 1 adjust the center blue lateral

On step 6 adjust the left blue lateral

On step 8 adjust the right blue lateral

Example

Red moves along an upper right to lower left line ↙
 Green moves along an upper left to lower right line ↘
 Blue moves vertically up and down ↓

— All 13 Steps —

Steps 1, 6 and 8

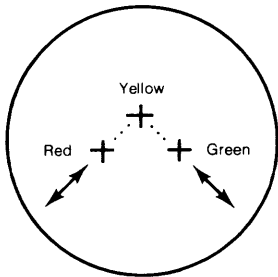

A
Converge Red and Green
to Make Yellow

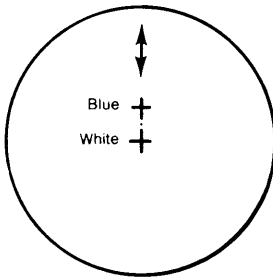

B
Converge Blue
to Make White

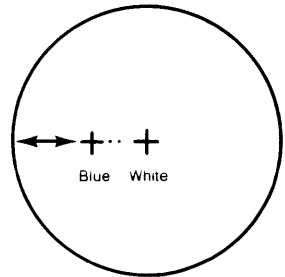

Use Blue Lateral to
Move Blue Left or
Right as Necessary

Raster Position

Two adjustments, horizontal and vertical centering (A44), are used to position the raster in the center of the CRT screen.

The raster position adjustments are interactive with and affected by:

- Raster Size adjustments
- Raster Shape adjustments
- Purity adjustment

These adjustments should be performed after the initial raster position adjustment; then, recheck the raster position and readjust as necessary.

Set the switch on the A13 (A33, A53, or A54) assembly to the rear to display a full white alpha raster.

Procedure

1. Center the raster horizontally with the horizontal center control.
2. Center the raster vertically with the vertical center control.
3. Touch up convergence as necessary (see CONVERGENCE, page 6-6).
4. Check and perform, if necessary, the raster size, raster shape and purity adjustments.

Raster Size

Two adjustments, raster width and raster height are used to dimension the raster to the proper size.

You may have to readjust the raster position slightly after sizing.

Set the switch on the A13 (A33, A53, A54) assembly to the rear to display a full white alpha raster.

Procedure

1. Adjust the raster width and height so that the displayed raster is the same size as shown in drawing.
2. Adjust the raster shape and readjust the raster position as necessary.

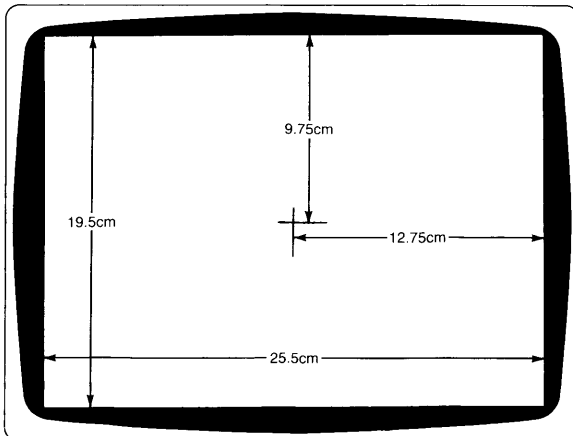

Raster Shape

Once the raster is positioned and sized, the raster shape adjustments are used to straighten and proportion the raster sides to obtain a rectangular raster.

The raster shape adjustments interact with each other and may affect the raster size.

Set the switch on the A13, (A43, or A53) assembly to the rear to display a full white alpha raster.

Procedure

1. Adjust the phase control to make the edges of the raster equal in height.

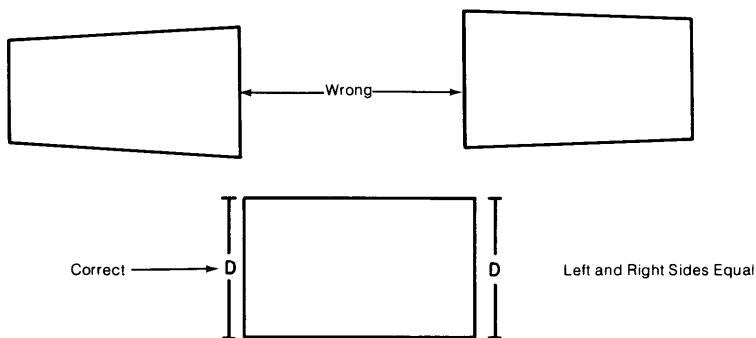

Note

If the raster appears tilted after this adjustment (with the bezel seated evenly), remove the bezel assembly, loosen the four screws securing the CRT assembly and tilt the CRT assembly as necessary to correct the raster tilt. Tighten the four screws securing the CRT assembly, reseal the bezel assembly evenly and recheck the raster tilt.

2. Adjust the top and bottom ratio control to produce an equal but opposite shape on the top and bottom edges of the raster.

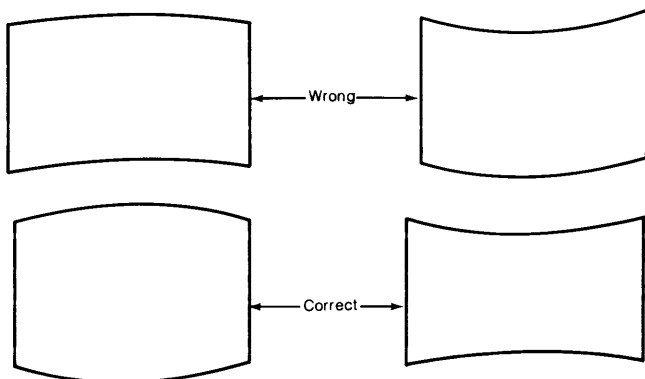

Equal but Opposite Shapes of Top and Bottom Edges

3. Adjust the side pincushion control (A44) to straighten the left and right edges of the raster.

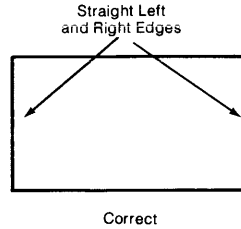
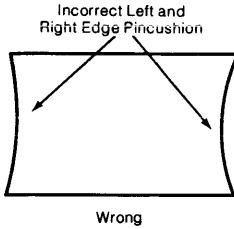

4. Adjust the top and bottom pincushion control (A44) to straighten the top and bottom edges of the raster.

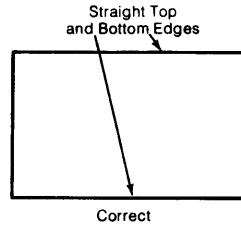
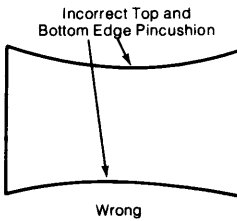

5. Recheck adjustments made in steps 1 through 4; then recheck the raster size adjustments to see if they have been effected.

Vertical Linearity

These adjustments affect the vertical raster size. Recheck the raster size after making these adjustments.

Refer to drawing 1 below and mark the center of the CRT screen with a wax marker or pencil. Do not use a felt or magic marker. Drawings 2 and 3 show the relative spacing for the vertical and horizontal patterns.

For the 9845B/C computer use the Binary Test Cartridge (Rev. C or newer); or for the 9000 computers use the 9000 Integrity Test Disc, to display the test patterns.

1. Remove the top cover of the display. Set the switch on A13, A33, A53, or A54 to its center (normal) position.
2. Adjust the vertical center control to align the center line of the display with the center of the CRT found above.
3. Refer to drawing 2 and adjust the vertical height and null controls as necessary to position the outside lines of the display. Assure that the center line remains at the center of the CRT.
4. Adjust the vertical linearity control to obtain near equal spacing between the horizontal line in the areas between the Top, Center, and Bottom lines.
5. Display the focus pattern. Readjust the null and linearity controls as necessary to obtain equal character height throughout the pattern.
6. Display the horizontal centering pattern. Adjust the horizontal centering and the horizontal size to obtain the pattern in drawing 3.

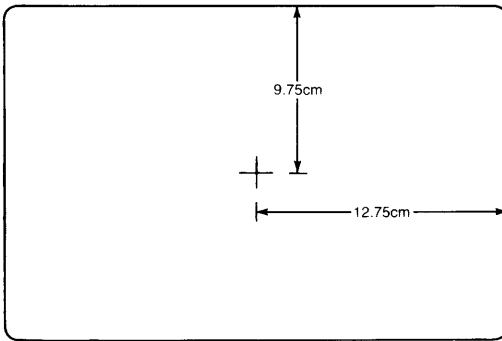

1

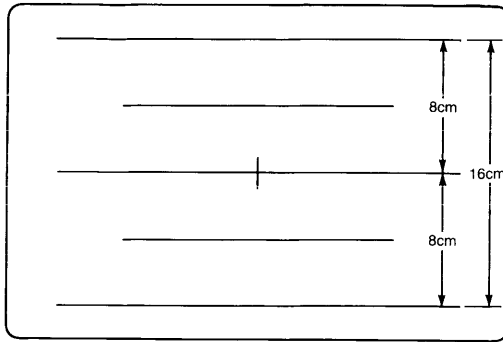
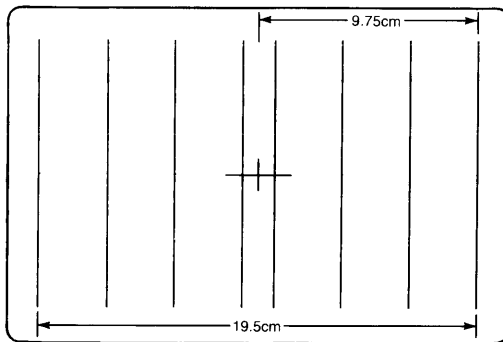
**2****Vertical Centering****3****Horizontal Centering**

Final Convergence

As the previous adjustments may have affected convergence, a final convergence adjustment should be made at this time (see CONVERGENCE, page 6-6).

Chapter 7

Peripherals

Chapter 8

Replaceable Parts

Repair Philosophy

Most 98770A repairs are done by replacing the faulty assembly. The old assembly is returned for repair in some cases (exchange program) and is thrown away in others. In a few cases, a faulty assembly can be repaired to the component level either on-site or at the local field office. This procedure is recommended only when replaceable components are not soldered in or when the probability of inducing further damage in the course of doing the repair is minimal. All components which may be replaced by the CE are listed as level 2 parts under the assembly part number in the parts list. Other failures should be repaired at the assembly level. All exchange parts are noted as such in the parts lists.

8-2 98770 Replacement Parts

98770 Part Numbers

Assembly Level	Reference Designator	CD	HP Part No.	TQ	Description
1		4	0490-1235	1	Power Switch Relay
1		8	1970-0050	1	Spark Gap
1		8	2110-0051	1	Fuse - 10 Amp Normal Blow (for 110V)
1		3	2110-0056	1	Fuse - 6 Amp Normal Blow (for 220V)
1		3	2110-0543	1	Fuse Holder
1		5	2110-0545	1	Fuse Holder Cap
1		1	3101-2298	2	Voltage Selector Switch
1		4	9135-0123	1	Line Filter
1		7	98770-61601	1	Light Pen Cable Assembly
1		8	98770-61602	1	Upper Transistor Socket and Cable
1		9	98770-61603	1	Lower Transistor Socket and Cable
1		0	98770-61604	1	Soft Key Cable (from motherboard)
1		1	98770-61605	1	Intensity Control Assembly
2		9	2100-3833	1	Variable Resistor 250K
2		5	5040-8149	1	Thumb Wheel
1		2	98770-61606	1	High Voltage Power Cable
1		3	98770-61607	1	A6 Assembly Power Cable
1		4	98700-61608	1	Start-Up Transformer
1		0	98770-61612	1	Power Supply Connector Assembly
1	A0	5	98770-66500	1	Motherboard
2	R1	8	0698-3441	1	Resistor - 215 ohm, 1%, 1/8 watt
2	J13	6	1251-0599	1	Connector - 3 pin male
2	J18.27	6	1251-1365	2	Connector - PC 44 contact
2	J17.25.28.31	8	1251-2026	4	Connector - PC 36 contact
2	J1.4.23	9	1251-2035	5	Connector - PC 30 contact
2	J15.16.19.24. J26.29	4	1251-2915	6	Connector - PC 50 contact
2	J7.8	5	1251-2916	2	Connector - PC 36 contact
2	J14	7	1251-3198	1	Connector - 15 pin male
2	J9.11	7	1251-3403	2	Connector - PC 20 contact
2	J22	3	1251-3475	1	Connector - 10 pin male
2	J20.21	6	1251-3767	2	Connector - 7 pin male
2	J5	4	1251-4672	1	Connector - 10 pin header
2	J12	8	1251-4882	1	Connector - 7 pin post-type
2	J10	8	1251-5153	1	Connector - single contact
2	J6	1	1251-7623	1	Connector - 10 pin male
1	A1	6	98770-66501	0	Motherboard - old version
1	A2	7	98770-66502	1	Convergence Waveform Assembly
1	A3	8	98770-66503	1	Convergence Output Assembly
1	A4	9	98770-66504	0	Deflection-HV Assy-old version-See 98770-66544
1	A5	0	98770-66505	1	Transistor/Heat Sink Assy-Exchange part 98770-69505
2	Q15.16.19.23 Q29.33	9	1853-0059	6	Transistor - 2N3791
2	Q1	8	1853-0305	1	Transistor - 2N5875
2	Q9	4	1853-0351	1	Transistor - 2N6053
2	Q4	7	1854-0063	1	Transistor - 2N3055
2	Q10.26.28	0	1854-0264	3	Transistor - 2N3715
2	Q21.34	5	1854-0848	2	Transistor - 2N6584
1	A6	1	98770-66500	1	video Amp Assy-Exchange part 98770-69500
1	A11	8	98770-66511	1	Vector Generator Assy-Exchange part 98770-69511
1	A13	0	98770-66513	0	Display Logic Assy-old version-see 98770-66533
1	A32	3	98770-66532	1	Graphics Memory Assy-Exchange part 98770-69532
2	U1.48	8	1818-0391	48	IC-16K RAM
1	A33	4	98770-66533	1	Display Logic Assy-Exchange part 98770-69533
1	A44	7	98770-66544	1	Deflection-HV Assy-Exchange part 98770-69544
1	A53	8	98770-66553	0	Display Logic Assy-Katakana old version-see 98770-66554
1	A54	9	98770-66554	1	Display Logic Assy-Katakana Exchange part 98770-69554
1		2	98770-67901	1	High Voltage Assy
2		8	9100-0485	1	High Voltage Transformer
1		6	98770-67971	1	CRT Yoke Assy-Exchange part 98770-69971
1		7	98770-67980	1	Power Supply Assy-Exchange part 98770-69980
1		0	98770-68501	1	AC Fan Assembly

Assembly Level	Reference Designator	CD	HP Part No.	TQ	Description
1		1	98770-68502	2	DC Fan Assembly
1		6	98770-69505	1	Transistor/HS Assy-Exchange
1		7	98770-69506	1	Video Amp Assy-Exchange
1		4	98770-69511	1	Vector Generator Assy-Exchange
1		9	98770-69532	1	Graphics Memory Assy-Exchange
1		0	98770-69533	1	Display Logic Assy-Exchange
1		5	98770-69554	1	Display Logic Assy-Exchange
1		0	98770-69971	1	CRT/Yoke Assy-Exchange
1		1	98770-69980	1	Power Supply-Exchange
1		1	98775-66501	0	Light Pen Control Assy-old version-See 98775-66504
1		4	98775-66504	1	Light Pen Control Assy
1		1	98775-67971	1	Light Pen Assy-Exchange part 98775-69971
1		5	98775-69971	1	Light Pen Assy-Exchange

Motherboard Connectors

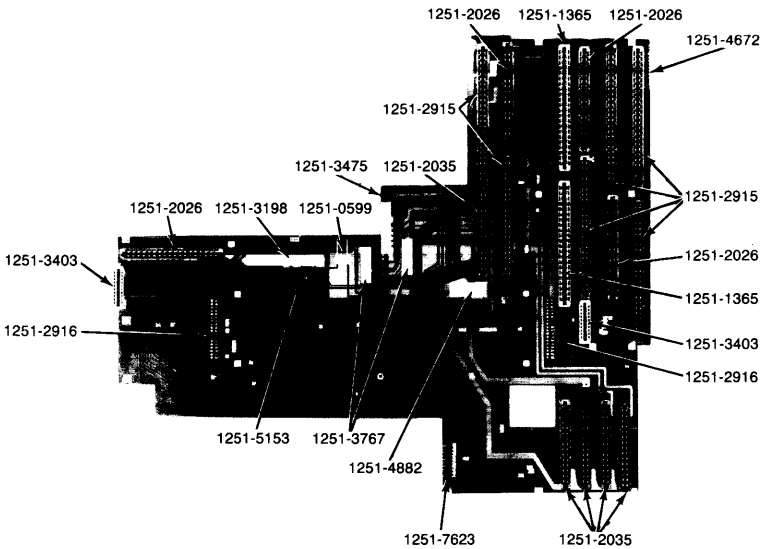

A5 Transistors

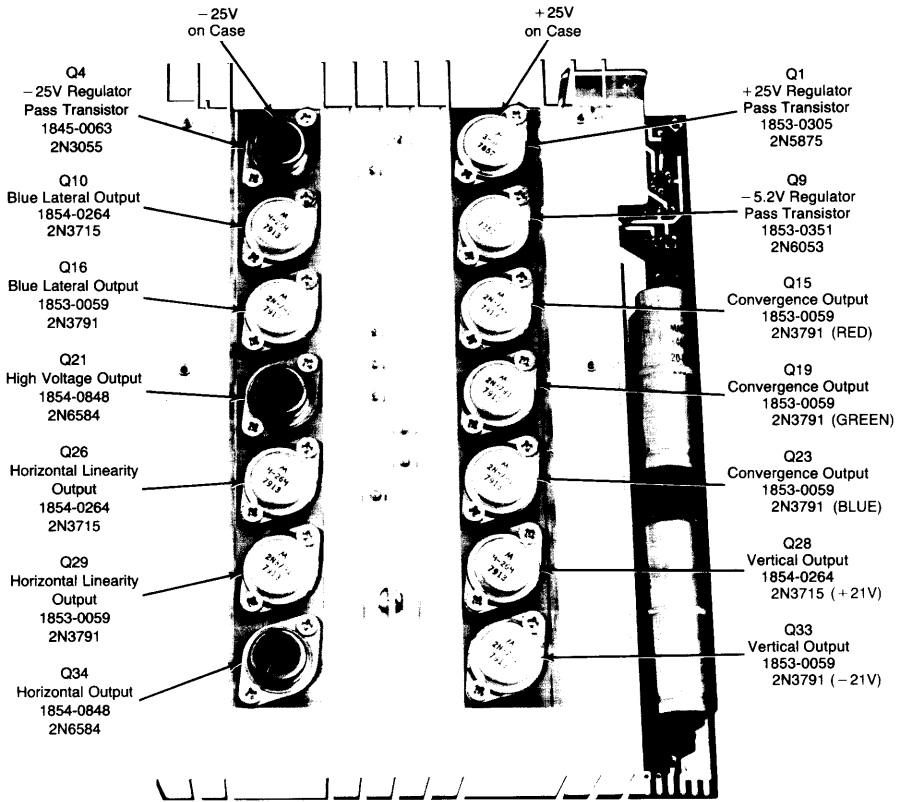

Chapter 9

Diagrams

Assemblies Under the Top Cover

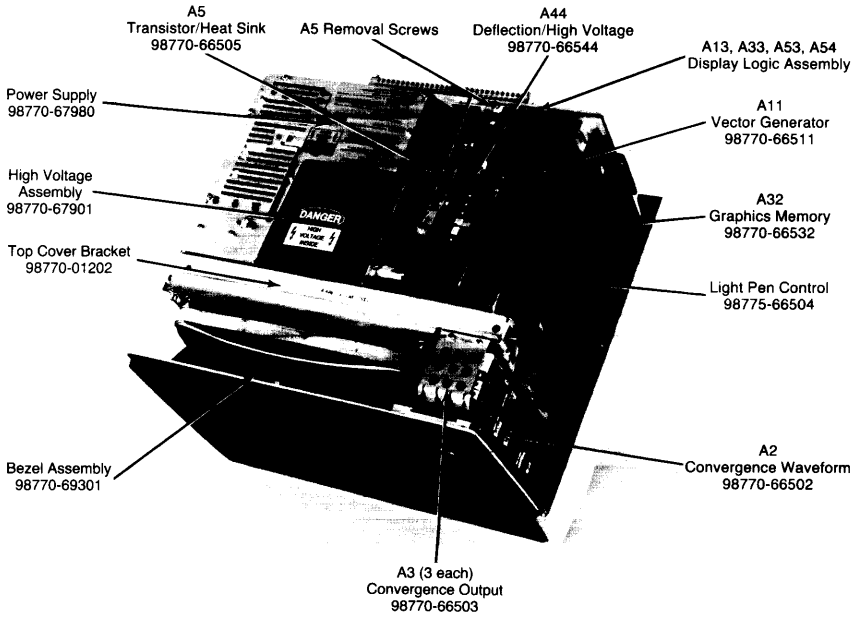

Rear Panel Assemblies

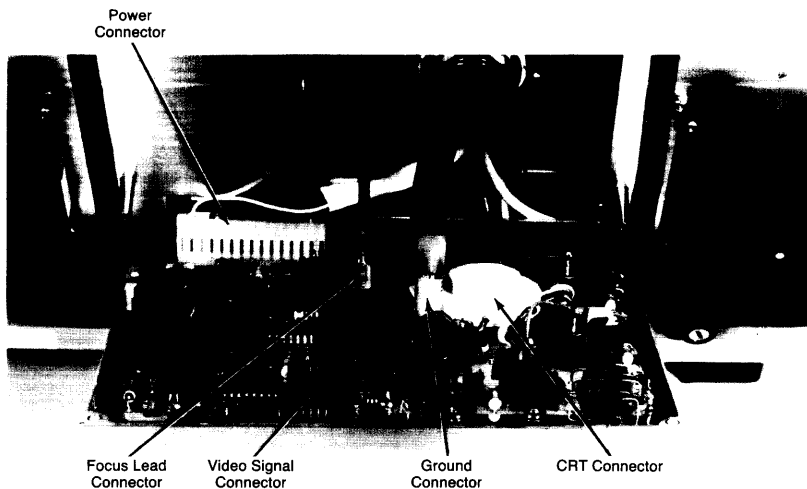

Chassis Assemblies

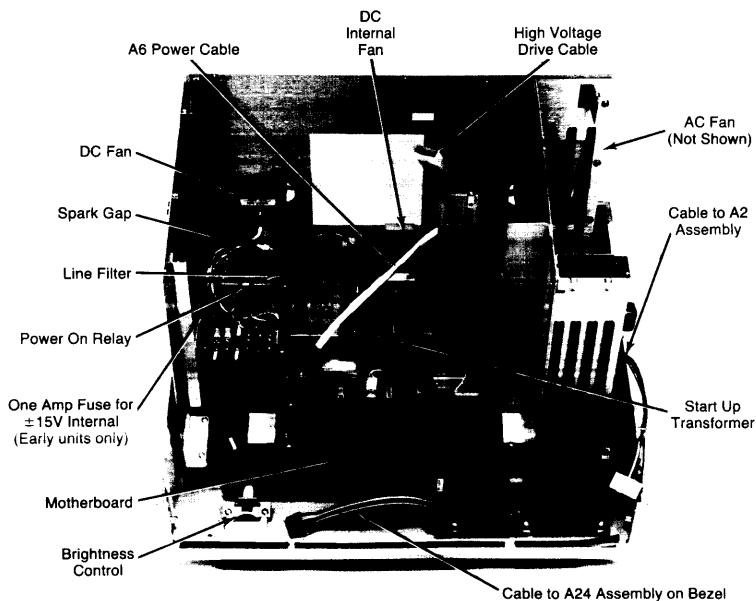

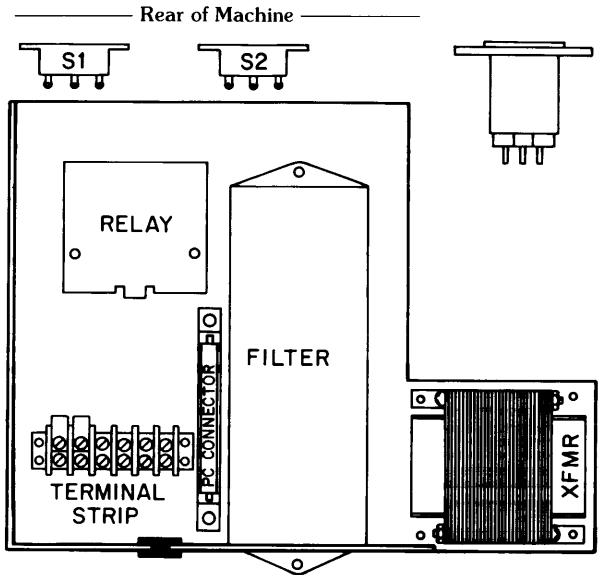
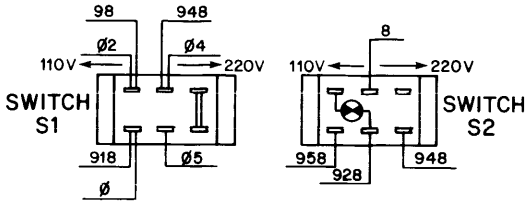

See wiring diagrams that follow.

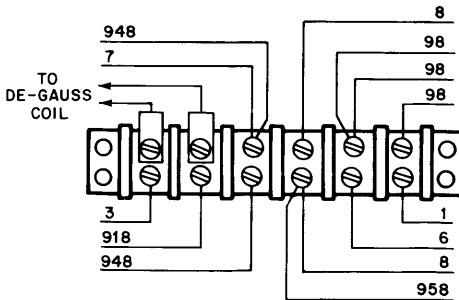

Primary Wiring

9-4 98770 Diagrams

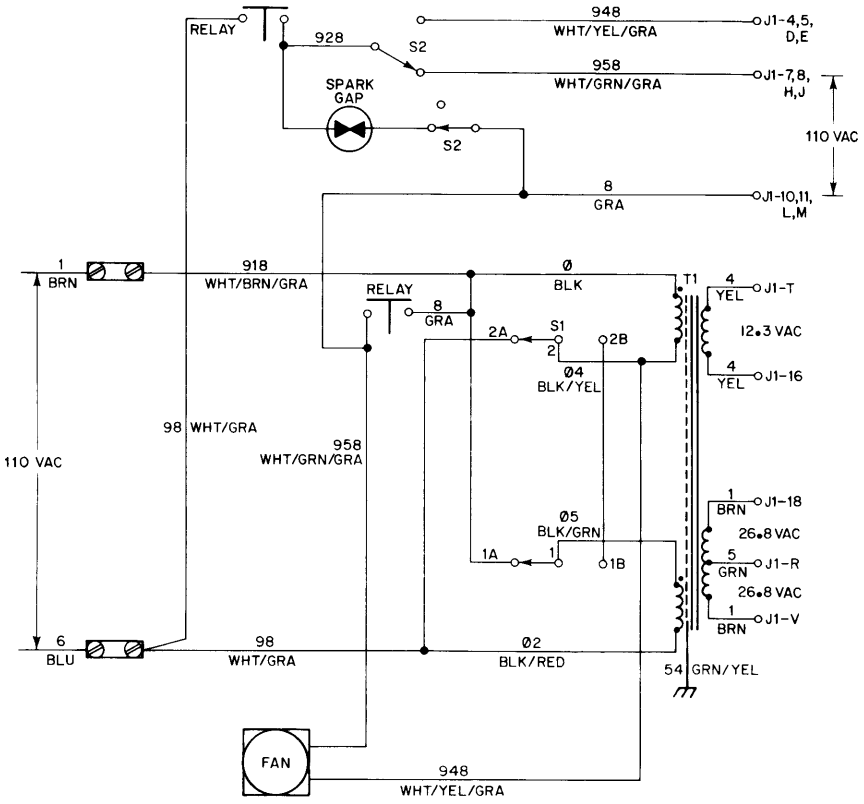

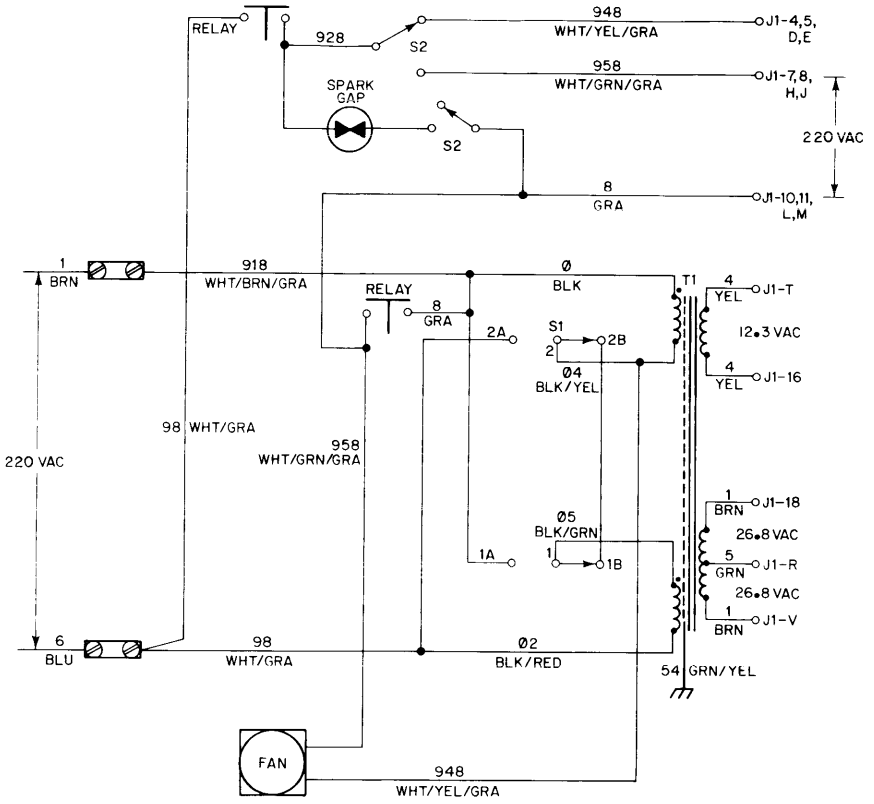

Switch in 220V Position

CRT Handling

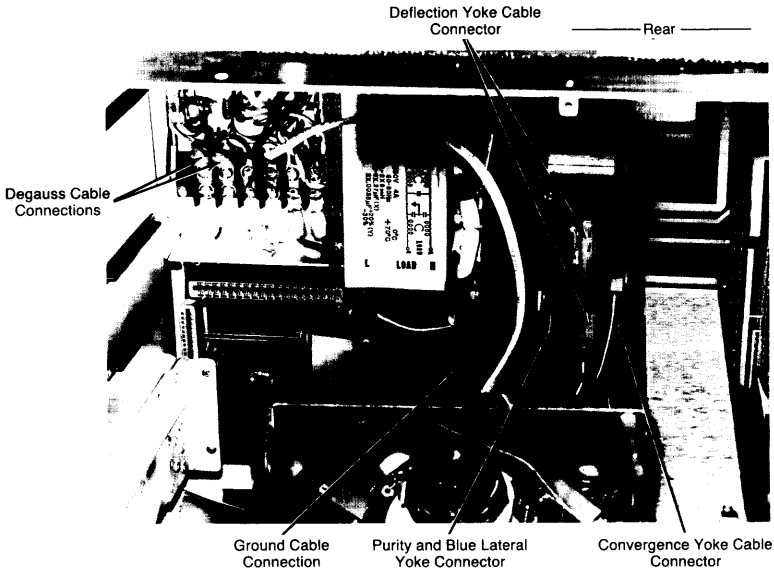

CRT/Yoke Cables

CRT Assembly Storage Position

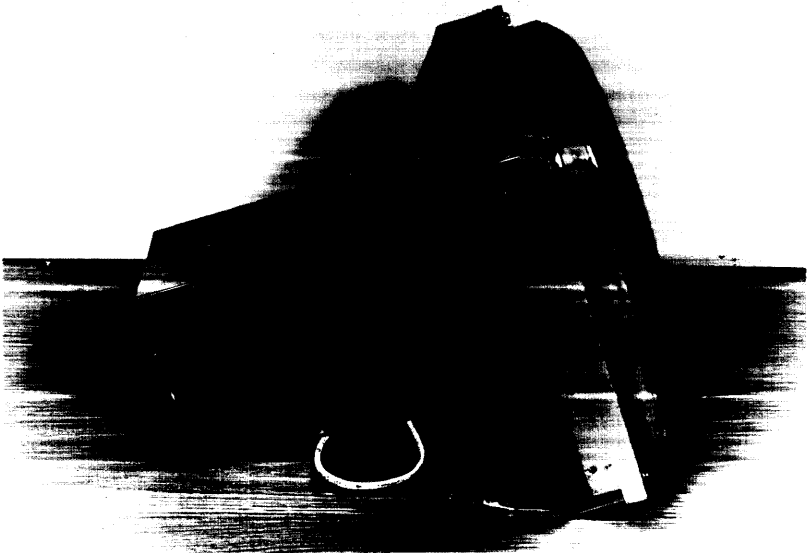

Light Pen Installation

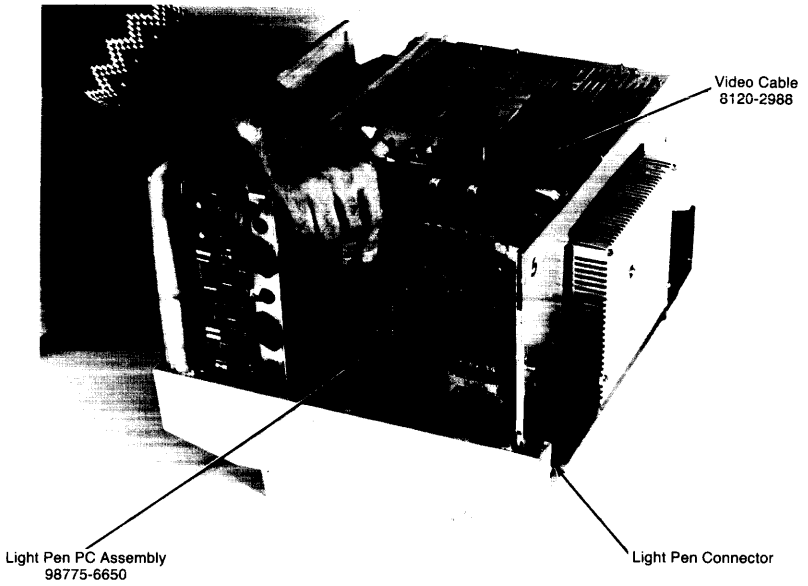

Light Pen PC Assembly Installation

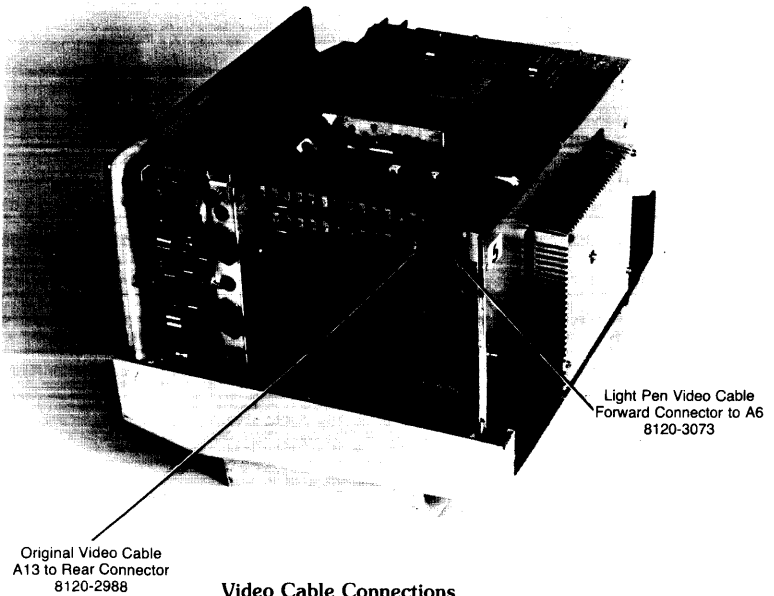

Power Supply Checks

The power supply test points are shown in Figure 3-2. Table 3-2 lists the voltage tolerances for each supply.

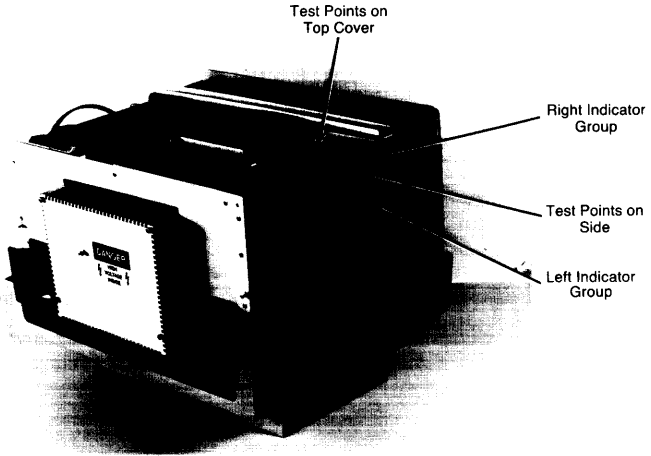

Power Supply Test Points

Power Supply Assemblies

The power supply assembly (98770-67980) is an exchange item; however, here is a list of the power supply PC assemblies and the circuits found on each assembly.

98770-66507 (A7) Primary Assembly

Degauss

Energy Storage Circuit (less 2 big capacitors)

Switching transformers

Switching regulator filter inductors

Surge limit relay

98770-66508 (A8) Filter Capacitor Assembly

Filter capacitors for the output voltages of the switching regulators. Voltages enter the 98770 motherboard via this assembly.

98770-66509 (A9) Control Assembly

Filament supply rectifiers and filter

Regulators for filament, ± 15 INT and +12 supplies

Pulse width modulators

Frequency response shaping

HSYNC synchronizer (phase-locked loop)

Voltage/current sense

LED indicator drivers

98770-66515 Switching Assembly

Current sense transformers

Switching transistors for the switching regulators

98770-66516 Rectifier Assembly

Rectifiers for the switching regulators

Power Supply Block Diagram

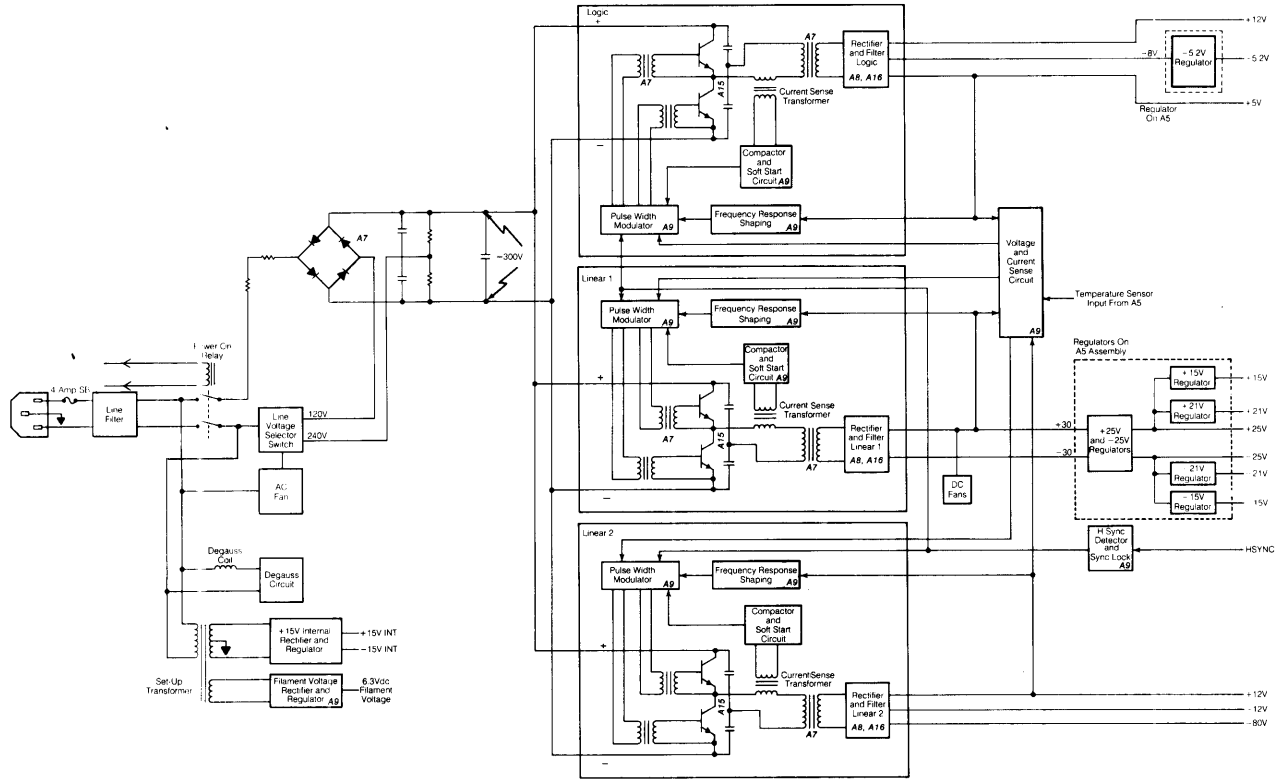

Mnemonic	Description	Mnemonic	Description
ABL	Alpha Blanking	LXA	Load X Address
AS	Alpha Select	LXC	Load X Cursor Position
AVC	Address Valid Clear	LYA	Load Y Address
BADR	B Address Lines	LYC	Load Y Cursor Position
BAV	Blue Alpha Video	M1 Video	Video Data From Memory 1
BGV	Blue Graphics Video	M2 Video	Video Data From Memory 2
BLKG	Blinking	M3 Video	Video Data From Memory 3
BR	Bus Request	MC	Memory Select Line 0
BV	Blue Video	MS0	Memory Select Line 1
BVD	Blue Video Data	MS1	Memory Synchronization
C80	80s Character	MSYNC	
CAS	Column Address Strobe	NCS	N Counter Select
CEBG	Chained External Bus Grant	NL	New Line
CL		NP	New Page
COLOR	Color Select Lines	NW	New Word
CRT	CRT Status Line	NWE	New Word Enable
CURS	Cursor	OC	Output Clock
CSTM	Internal Start Memory Cycle	OL	Output Latch
DO	Memory Data Out Lines	OS	Output Strobe
DOUT	Data Out	PA	Peripheral Address Lines
DMAR	Direct Memory Access Request	PBR	Peripheral Bus Request
DSP	Display	PEBG	Peripheral External Bus Grant
EBG	External Bus Grant	PSMC	Peripheral Synchronous Memory Complete
EOL	End of Line	RAS	Row Address Strobe
FB	Full Brightness	RAV	Red Alpha Video
FLB	Full Line Buffer	RGV	Red Graphics Video
FLG	Flag	RNP	Reset New Page
GAV	Green Alpha Video	ROW	Row Select
GGV	Green Graphics Video	RV	Red Video
GS	Graphics Select	RVD	Red Video Data
GV	Green Video	SCM	Store Color Mask
GVD	Green Video Data	SGD	Select Graphics Display
HIGH	Highlight Select Lines	SLT	Select Line Type
HLT	Halt	SMC	Store Memory Control
HSYNC	Horizontal Synchronization	STM	Start Memory
IC1	Register Select Line 1	STS	Status
IC2	Register Select Line 2	TCK	Buffered Mainframe Clock
IDA	Instruction, Data, Address Bus Lines	UL	Underline
INIT	Initialize	VGC	Vector Generator Clock
INT	Interrupt	V Busy	Vector Generator Busy
IOSB	Input / Output Strobe	V Ready	Vector Point Ready
IRH	High Level Interrupt	V SYNC	Vertical Synchronization
IRQ	Interrupt Request	WE	Write Enable Lines
IS	Input Strobe	WW	Write Word
LDA	Load Address	X ADR	X Memory Address Lines
LEP	Load End Point	Y ADR	Y Memory Address Lines
LIOD	Latched IOD Bus Lines (Internal)	Y SCAN	Y Timing Chain Output Lines
LTE	Line Type Enable		

Replaceable Mechanical Parts

The replaceable mechanical parts of the HP 98770A Display are listed in the following table. The table is organized to list the parts that go together in groups. The major assembly is listed first and the hardware needed to attach it to adjoining assemblies is listed next. The "Ref. Desg." is keyed to the exploded view drawing that appears after the table. Not all parts listed appear on the drawing.

Selected Assemblies Part Numbers

Assembly Level	Reference Designator	CD	HP Part No.	TQ	Description
	1		98770-64405	1	Top Cover
			3050-0066	2	Flat Washer
			0515-0067	2	Screw, M3.5 X 0.6-10mm, Panhead
	2		98770-64404	1	Front Bezel
	2a		3101-2400	1	Soft Key Assembly
			3050-0066	3	Flat Washer
			0535-0007	3	Nut, M3.5 X 0.6, Hex
	2b		98770-61206	1	Convergence Panel
	2c		NA	1	Switch Bracket Assembly. Includes Next Two Parts:
			1600-1066	1	Bracket, Switch
			0490-0744	1	Switch, Reed
			0624-0314	2	Screw, Panhead, Plastite
			3050-0066	1	Flat Washer
			0624-0347	3	Screw, Flathead, Plastite
	2d		5041-2386	1	Door
			9164-0119	2	Magnet (on rear of door)
	3		98770-64401	1	Base
	3a		98780-67977	1	Locking assembly, Right Foot
	3b		98780-67978	1	Locking Assembly, Left Foot
			7120-8677	Set	Error Cards
			7101-0569	1	Cover, Error Cards
			0624-0400	4	Screw
	3c		98770-61605	1	Brightness Control Assembly
			2190-0918	2	Lock Washer
			0624-0403	2	Screw
	3d		NA	2	Cover Hold Down Latch. Includes the next four parts:
			1460-1982	1	Pawl spring
			1480-0083	1	Pawl Pin
			1600-1310	1	Bracket
			1600-1327	1	Latch Pawl
			2190-0918	4	Lock Washer
			0624-0403	4	Screw
	3e		98770-68502	1	DC Fan
	3f		98770-01205	2	Mounting Brackets
			2190-0918	4	Lock Washer
			0515-0067	4	Screw, M3.5 X 0.6-10mm, Panhead
			3050-0066	2	Flat Washer
			2190-0918	2	Lock Washer
			0515-0068	2	Screw, M3.5 X 0.6-16mm, Panhead
	4		98770-66501	1	Mother Board
	4a		98770-66510	2	Interconnect Board
			2190-0918	14	Lock Washer
			0624-0403	15	Screw
	4b		98770-01208	1	Heat Sink Bracket
			0624-0403	2	Screw, Plastite
	4c		98770-66505	1	Heatsink Assembly
	4d		98770-66504	1	Deflection Board
	4e		98770-66513	1	Display Logic Board
	4f		98770-66511	1	Display Vector Graphics Board
	4g		98770-66532	1	Graphics Memory Board
	4h		98770-66501	1	Light Pen Board

Assembly Level	Reference Designator	CD	HP Part No.	TQ	Description			
5	5a		98770-61201	1	Main Bracket Assembly			
			0624-0402	2	Screw, Plastite			
			0624-0403	2	Screw, Plastite			
			2190-0918	1	Lock Washer			
			98770-66503	3	Convergence Board			
			98770-66502	1	Waveform Board			
			1600-0907	1	Convergence Bracket			
			2190-0918	2	Lock Washer			
			0515-0067	2	Screw, M3.5 X 0.6 10mm, Panhead			
			0515-0066	1	Screw, M3.5 X 0.6-6mm, Panhead			
5d			98770-01202	1	Top Cover Bracket			
			2190-0918	2	Lock Washer			
			0515-0066	1	Screw, M3.5 X 0.6-6mm, Panhead			
			3050-0066	2	Flat Washer			
			0380-0006	1	Round Spacer			
			0403-0002	1	Foot Bumper			
			0515-0069	1	Screw, M3.5 X 0.6-25mm, Panhead			
			98770-01206	1	P.C. Tie Down Bracket			
			0515-0080	2	Screw, M3.5 X 0.6-6mm, Flathead			
			1600-0989	1	LP Tie Down Bracket			
6	6a		98770-60201	1	Rear Panel Assembly			
			98770-61609	1	Primary Wiring Assembly. Includes The Next Seven Parts:			
			0360-1134	1	Barrier Block			
			0490-1235	1	Relay, Power Switch			
			1251-2357	1	AC Power Connector			
			3101-2298	2	Slide Switch			
			9135-0123	1	Line Filter			
			98770-61608	1	Power Transformer Assembly			
			98770-61612	1	Edge Connector Assembly			
			98770-68501	1	AC Fan			
6b			2190-0004	4	Internal Lock Washer			
			0515-0055	4	Screw, M3.0 X 0.5-6m, Panhead			
			98770-68502	1	DC Fan			
			3050-0716	1	Flat Washer			
			2190-0004	3	Internal Lock Washer			
			2190-0003	1	Lock Washer, Split-ring			
			0515-0055	4	Screw, M3.0 X 0.5-6mm, Panhead			
			98770-66506	1	Video Board			
			98770-00601	1	Rear Shield			
			2190-0918	4	Lock Washer			
6c			0515-0069	4	Screw, M3.5 X 0.6-25mm, Panhead			
			5041-2388	1	Rear Cover			
			3050-0071	2	Flat Washer			
			2190-0017	2	Lock Washer			
			0535-0006	2	Nut, M4.0 X 0.7, Hex			
			6d			98770-67970	1	Display Assembly
						3050-0071	2	Flat Washer
						2190-0918	2	Lock Washer
						0515-0066	2	Screw, M3.5 X 0.6-6mm, Panhead
						98770-04101	1	Tube Mount Bracket, Plate
98770-67901	1	High Voltage Assembly						
4040-1733	1	Baffle						
2190-0918	3	Lock Washer						
0624-0034	3	Screw, Self Tapping						
7	7a					98770-67980	1	Power Supply
			2190-0918	8	Lock Washer			
			0515-0066	2	Screw, M3.5 X 0.6-6mm, Panhead			
			0515-0067	6	Screw, M3.5 X 0.6-10mm, Panhead			
			8			98770-67970	1	Display Assembly
						3050-0071	2	Flat Washer
						2190-0918	2	Lock Washer
						0515-0066	2	Screw, M3.5 X 0.6-6mm, Panhead
						98770-04101	1	Tube Mount Bracket, Plate
						98770-67901	1	High Voltage Assembly
4040-1733	1	Baffle						
2190-0918	3	Lock Washer						
0624-0034	3	Screw, Self Tapping						

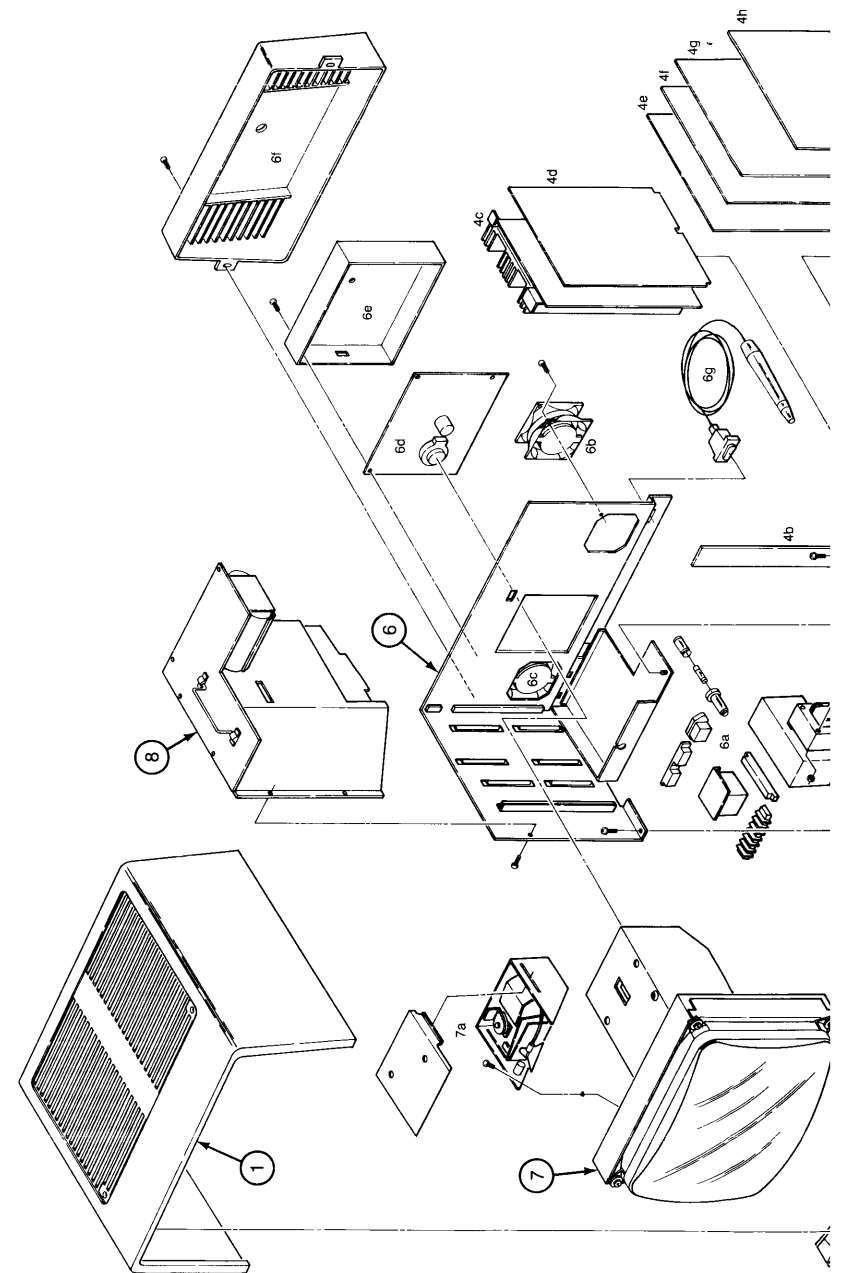

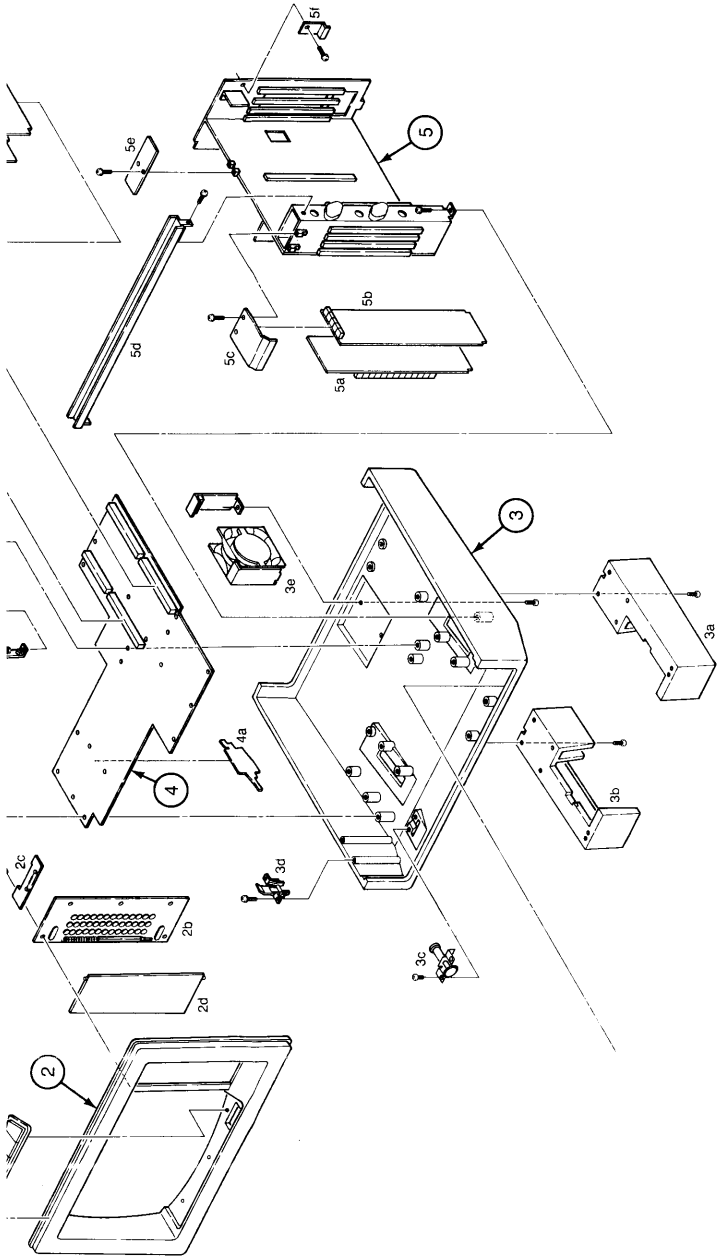

98770 Exploded View



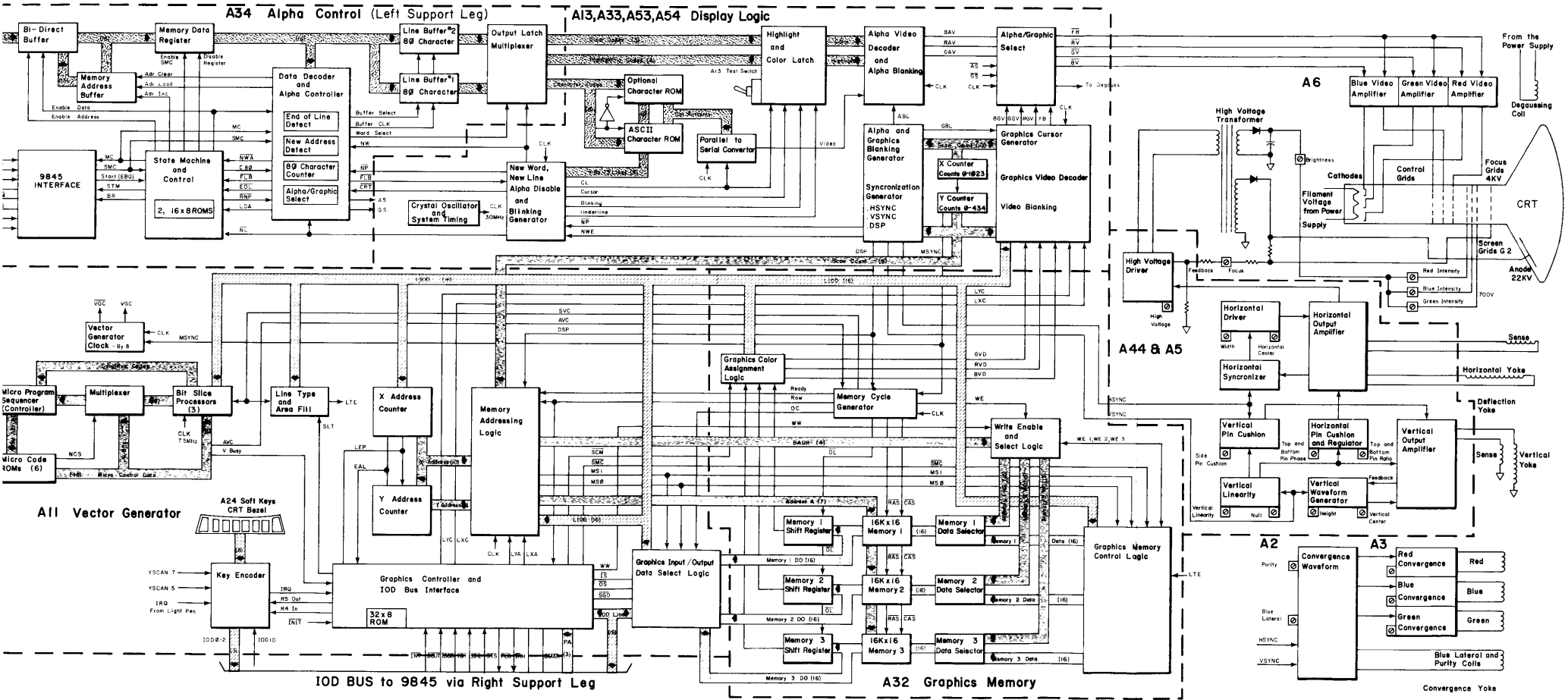

98770A Block Diagram

Chapter 10

Reference

Chapter 11

Service Notes

